

(No Model.)

2 Sheets—Sheet 1.

W. H. EASTON.  
ROUNDAABOUT.

No. 445,851.

Patented Feb. 3, 1891.

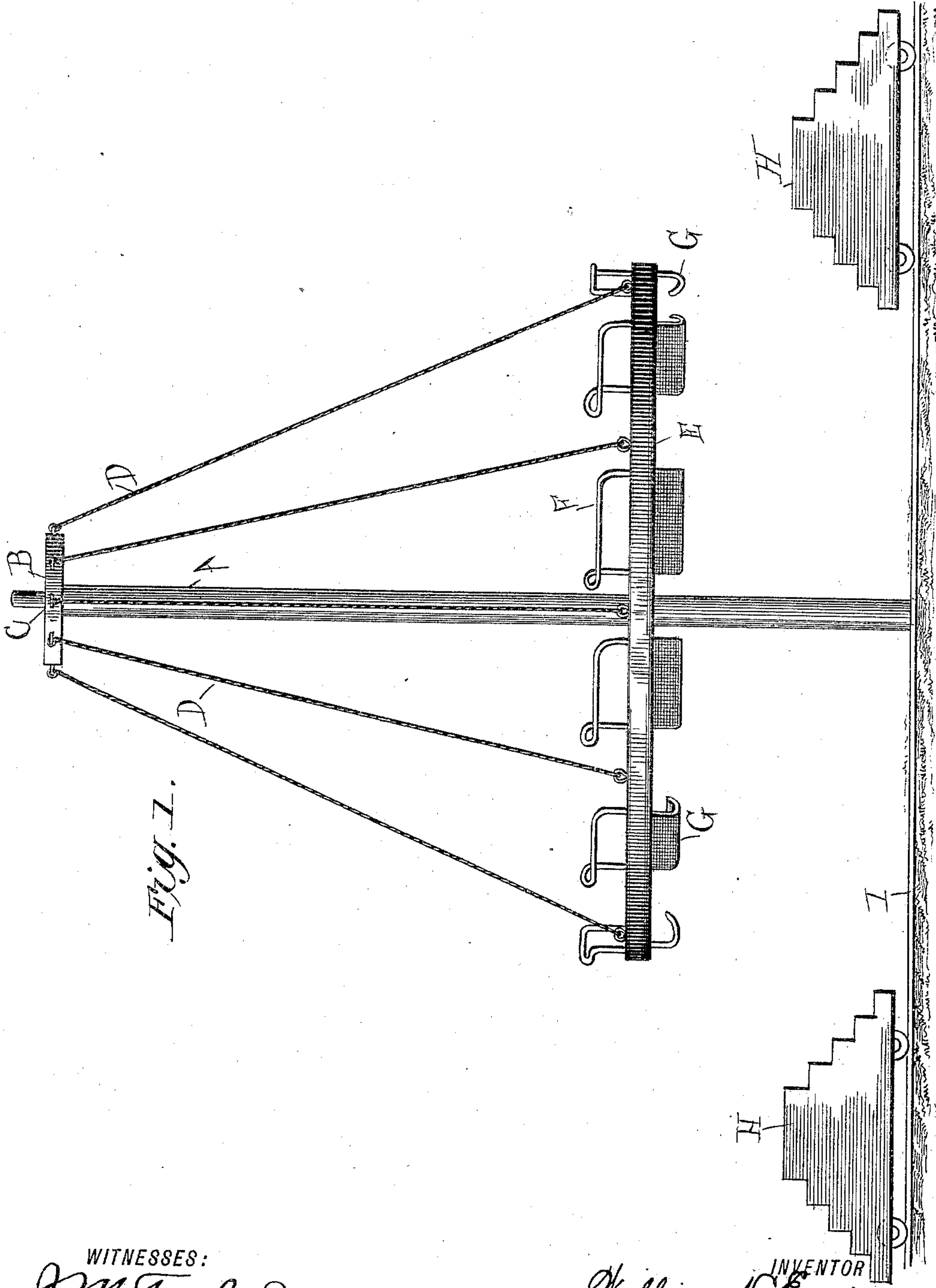

Fig. 1.

WITNESSES:

*J. M. Fowler*  
*C. Edw. Taub*

INVENTOR

*William H. Easton*

BY

*Chas. E. Barber*  
 ATTORNEY.

(No Model.)

2 Sheets—Sheet 2.

W. H. EASTON.  
ROUNDAABOUT.

No. 445,851.

Patented Feb. 3, 1891.

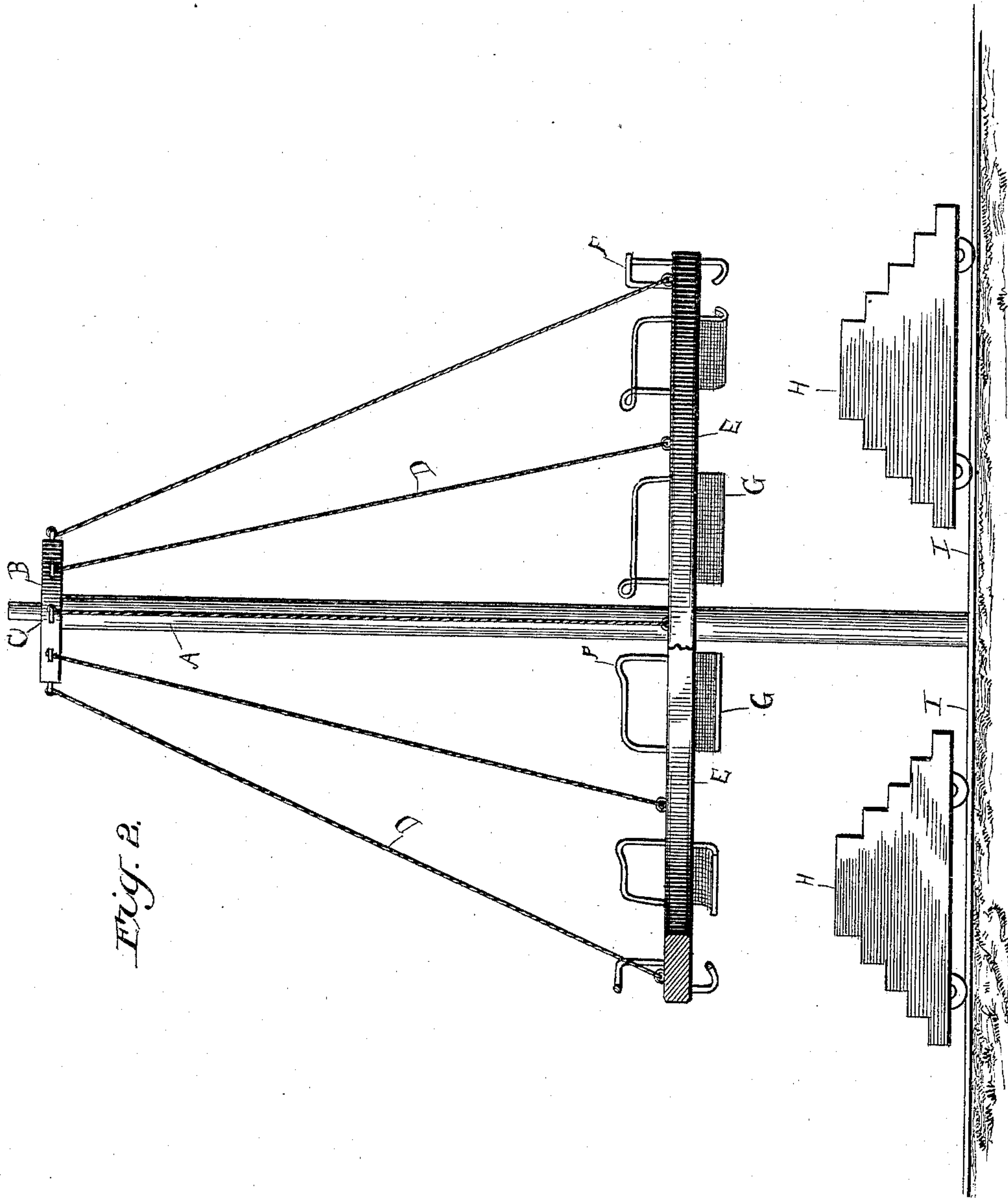

Fig. 2.

WITNESSES:

*J. M. Fowler Jr.*  
*C. Edw. Hunt*

INVENTOR.

*William H. Easton*  
BY  
*Chas. E. Barber*  
ATTORNEY.



# UNITED STATES PATENT OFFICE.

WILLIAM HARRIS EASTON, OF WASHINGTON, DISTRICT OF COLUMBIA.

## ROUNABOUT.

SPECIFICATION forming part of Letters Patent No. 445,851, dated February 3, 1891.

Application filed October 18, 1890. Serial No. 368,541. (No model.)

*To all whom it may concern:*

Be it known that I, WILLIAM HARRIS EASTON, a citizen of the United States, residing in Washington, in the District of Columbia, have  
5 invented certain new and useful Improvements in Roundabouts, of which the following is so full, clear, and exact a statement as will enable others skilled in the art to which my invention appertains to make and use the  
10 same, reference being had to the accompanying drawings, in which—

Figure 1 is a side elevation showing the steps away from the region of the seats. Fig. 2 is a similar view, with parts broken away,  
15 showing the steps in position beneath the seats.

The object of my invention is to provide a novel merry-go-round which will describe innumerable figures, the variation of which will  
20 produce the greatest merriment for the occupants of the plunger with the least expense of physical and mechanical force.

The invention consists in the novel construction, combination, and arrangement of  
25 parts, as will be hereinafter described, and particularly pointed out in the claim at the end of the specification.

In the accompanying drawings, A designates a vertical standard, the top of which forms a  
30 pivotal bearing-support for a plate or collar B, which is provided with a suitable perforation or socket C in its central portion, and which is provided all around with depending  
35 cables D, to the lower ends of which is secured a car E, upon which are arranged suitable arm-rests and back-supports F and suitable foot-rests and guards and skirt-protectors G. The car E is suspended from the  
40 cables a sufficient distance from the floor or ground to permit the car to be tilted, swung and rotated in every direction without liability of striking the ground or floor and without liability of injury to the car and its appurtenances or its occupants. A series of stairs  
45 H, sliding on suitable tracks I, may be slid under the car to enable the passengers to get

aboard, and the stairs are then pulled back out of the way and rotary motion imparted to the car around the line of its pivotal support. After the car has been set in motion the occupants of the seats on the car can influence  
50 and control the motion of the car and their own motion through the air without limit.

Instead of using a central standard to support the plunger, it is of course obvious that  
55 it may be suspended from a suitable pivotal support secured to any suitable structure in the wall or elsewhere above.

From the foregoing it will be readily understood that the car may be loaded and set in  
60 motion and the occupants will be treated to the greatest variety of motions and plungings without danger of injury and without the necessity of any considerable amount of applied power to start and operate the car, at  
65 the same time affording the greatest amusement and excitement and much physical benefit to the passengers.

In practice I prefer to use wire rope for cables; but it is of course understood that any  
70 other mechanical equivalent may be substituted therefor without departing from the spirit of my invention.

Having described the objects, uses, and advantages of my invention, what I believe to  
75 be new, and desire to secure by Letters Patent, and therefore claim, is—

In a roundabout of the character described, a pivotal support having a collar thereon  
80 which is provided with suitable cables depending therefrom, and an annular car having seats and back and foot rests and suspended by said cables on the collar, in combination with double inclined steps H, moving on radial tracks under the car, substantially  
85 as described.

In testimony whereof I affix my signature in presence of two witnesses.

WM. HARRIS EASTON.

Witnesses:

CHAS. W. DARR,  
J. R. SUTTON, Jr.