

(No Model.)

2 Sheets—Sheet 1.

W. H. THAYER.

RESERVOIR FOR HOLDING LIQUIDS UNDER PRESSURE.

No. 401,980.

Patented Apr. 23, 1889.

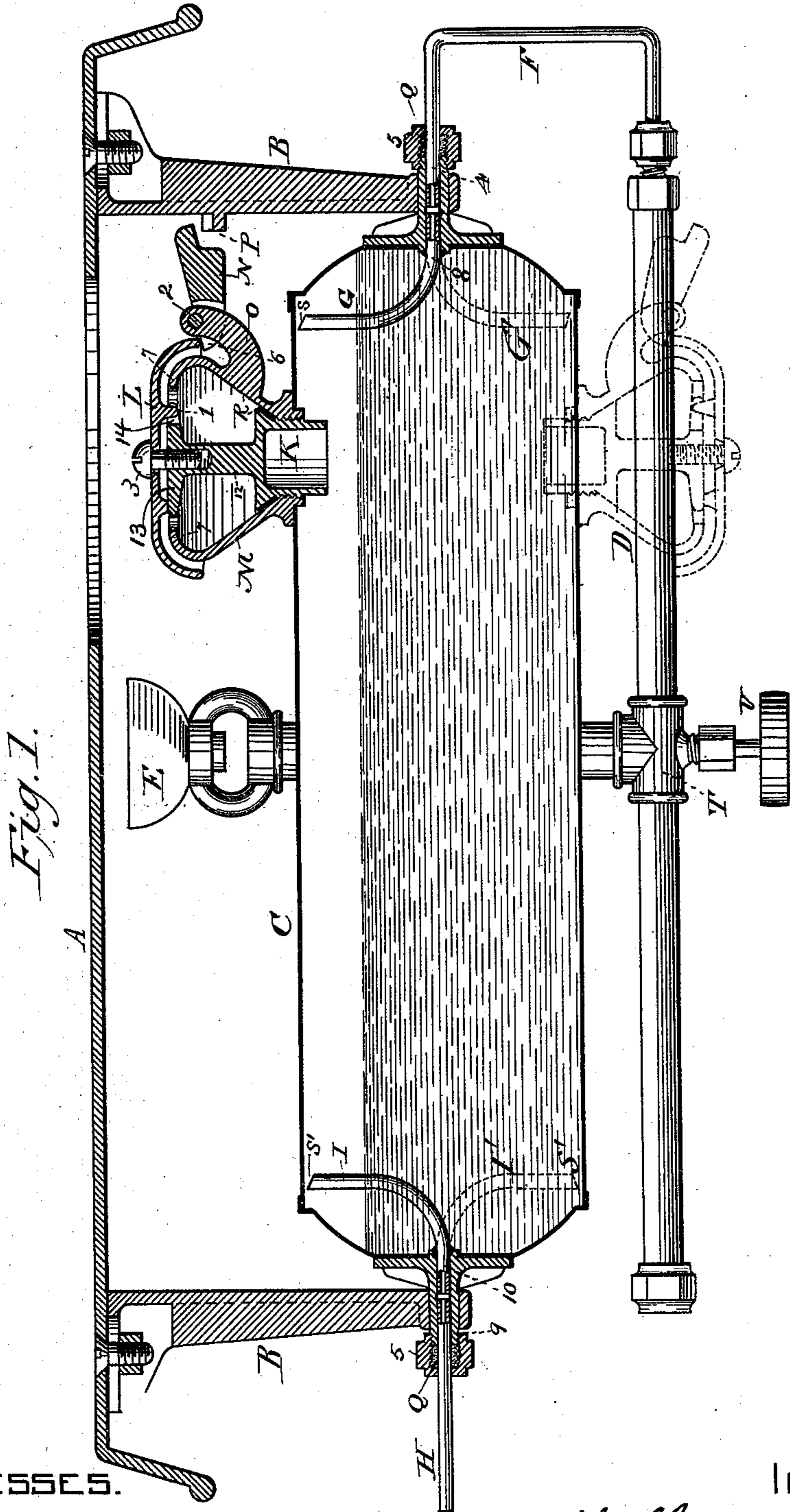

WITNESSES.

R. L. Roberts
Walter S. Campbell

INVENTOR.

William H. Thayer

(No Model.)

2 Sheets—Sheet 2.

W. H. THAYER.

RESERVOIR FOR HOLDING LIQUIDS UNDER PRESSURE.

No. 401,980.

Patented Apr. 23, 1889.

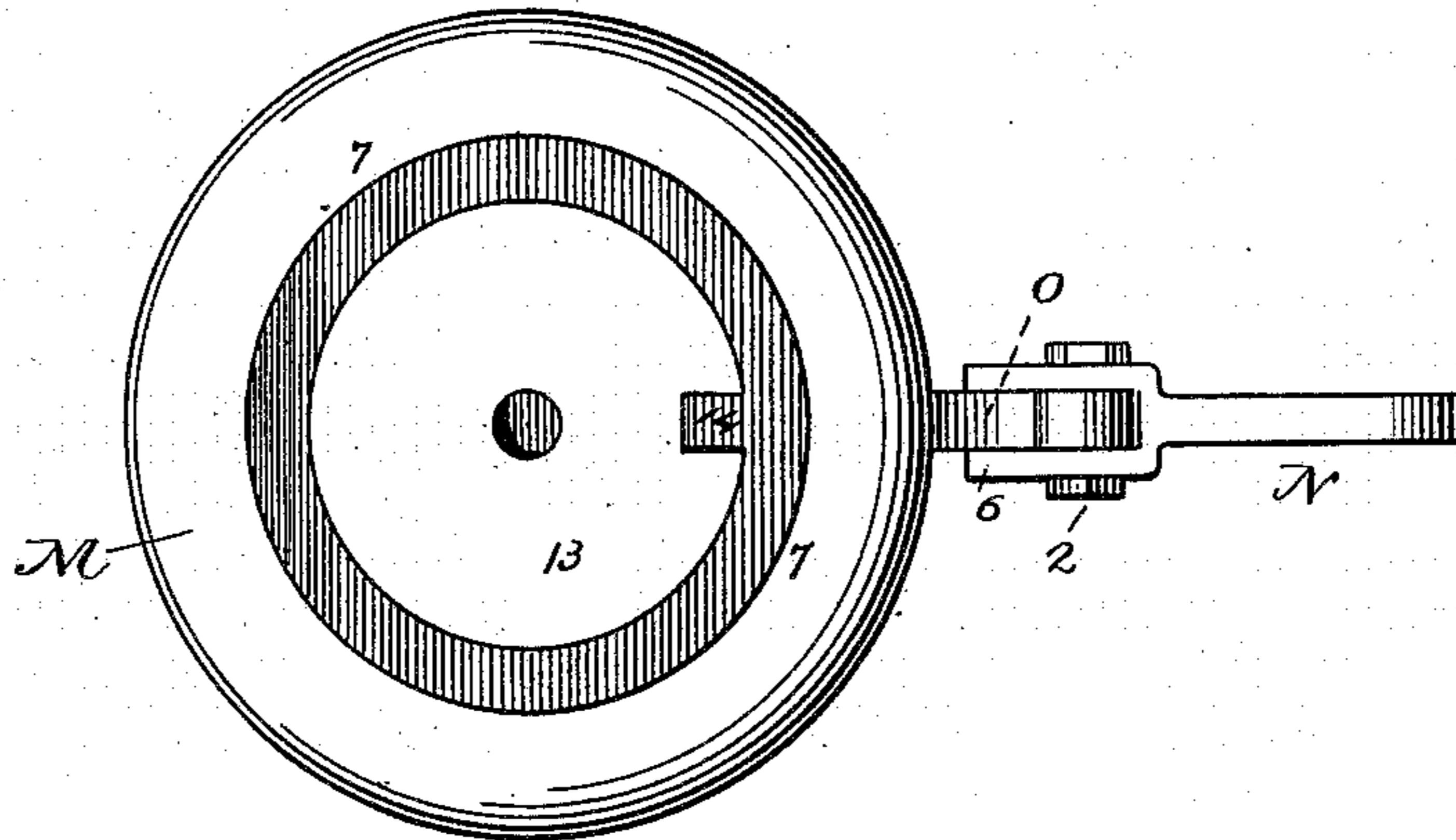

FIG. 2

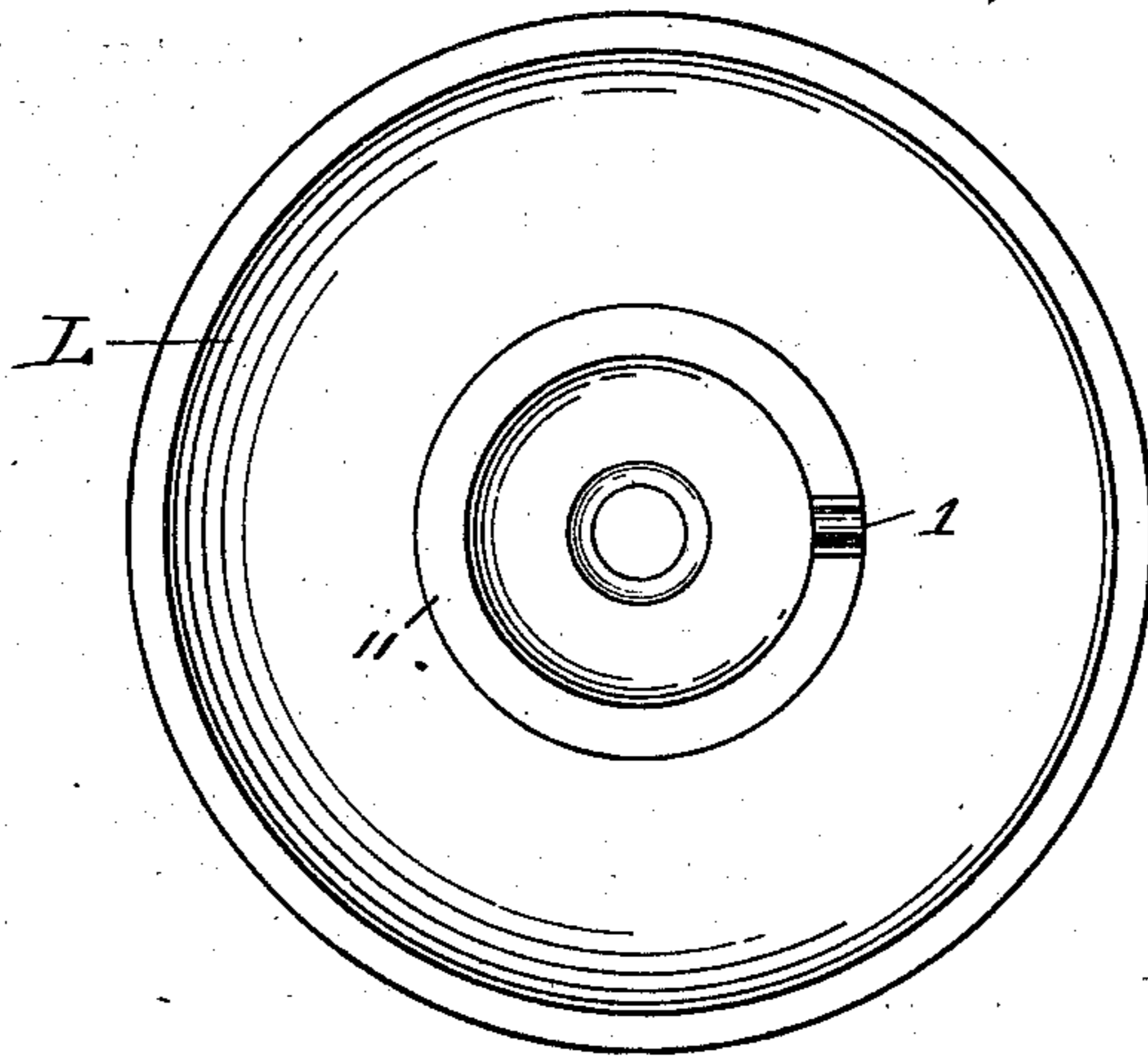

FIG. 3.

WITNESSES,
Walter S. Campbell.
Charles P. Wingerter.

INVENTOR
Wm. H. Thayer
By Geo. Roberts & Co. Atty.

UNITED STATES PATENT OFFICE.

WILLIAM H. THAYER, OF MELROSE, MASSACHUSETTS.

RESERVOIR FOR HOLDING LIQUIDS UNDER PRESSURE.

SPECIFICATION forming part of Letters Patent No. 401,980, dated April 23, 1889.

Application filed May 31, 1888. Serial No. 275,575. (No model.)

To all whom it may concern:

Be it known that I, WILLIAM H. THAYER, a citizen of the United States, and a resident of Melrose, in the county of Middlesex and State of Massachusetts, have invented certain new and useful Improvements in Reservoirs for Holding Liquids Under Pressure, especially adapted to holding hydrocarbon oils and distributing the same to stoves for burning, of which the following description, in connection with the accompanying drawings, is a specification.

The prime object of my invention is to provide a liquid-holding reservoir in which a pressure greater than that of the surrounding atmosphere can be easily maintained for a great length of time without material diminution, and it is especially applicable to reservoirs for holding oils under pressure for the purpose of supplying oil-burning stoves, particularly those intended for burning the more volatile hydrocarbon oils. For this purpose, in order to make a comparatively inexpensive reservoir and at the same time one capable of readily maintaining a pressure within it greater than that of the atmosphere, I construct my reservoir so that all its openings—both outlets and inlets—shall be beneath the liquid contained therein and thus sealed thereby when the reservoir is in position to discharge the liquid or to supply oil to the stove, and when the reservoir is in proper position for filling all of said openings shall be above the level of the liquid therein.

In the drawings I have illustrated my improved supply-reservoir as it may be connected with a hydrocarbon-oil-burning stove viewed from the rear, it being especially adapted for use therewith; but it will be readily seen that the outlet-pipe F may be connected with any other device or provided with a faucet, in which latter case the reservoir may be used for containing and delivering any liquid required to be held under pressure.

In reservoirs heretofore made which would maintain a pressure within them greater than that of the surrounding atmosphere for a long time it was necessary to construct the valves or inlet and outlet openings with great care and at correspondingly large expense in order to make such valves or openings "air-tight,"

which is a matter of considerable difficulty; but my improvements enable me to construct a reservoir with its inlets and outlets closed by valves of ordinary construction packed as liquid-valves usually are by reason of the fact that when the reservoir is in proper position for operation all of its valves and openings are beneath the level of the liquid contained therein.

In the drawings, Figure 1 represents my improved reservoir supported by hangers attached to the top of an oil or vapor burning stove all in section, the reservoir being divided longitudinally through its center. Figure 2 is an enlarged plan view of the filling-spout M and latch N, with the disk L removed. Figure 3 is an enlarged inverted plan view of the disk L.

A is the top of the stove; B, the hangers for supporting the reservoir. C is the reservoir; D, the pipe to which the burners E are attached; F, the supply-pipe which conducts the oil or naphtha from the reservoir to the pipe D.

H is a pipe leading from an air-pump to the reservoir to produce pressure therein.

I is a pipe within the reservoir, made fast at 10 within its hollow journal—preferably by soldering—and through which the compressed air issues into the reservoir at s'. Within the hollow journal at the other end of the reservoir the bent pipe G is made fast at 8, and when the reservoir is turned from the position shown in Fig. 1, with the spout M and pipes G I in full lines to that in which they are shown in dotted lines—that is, with the filling-spout M beneath the reservoir—the liquid will enter at the opening s and be forced out into the pipe F. The hollow journals of the reservoir are supported in bearings at the ends of the hangers B, and the ends 4 and 9 of the pipes F and H, respectively, are inserted into the said journals and proper joints made by means of the nuts 5, containing the packing Q.

The filling-spout M, which I use in connection with my reservoir, is of peculiar construction, and is attached to the reservoir upon the side near which the pipes G and I terminate, so that the inlet and outlet openings are all upon the same side of the reservoir into whatever position it is turned.

I make the spout M flaring outward from

its connection with the reservoir, and at its outer edge turn it inward, as at 7, so as to somewhat constrict the mouth of the spout, in order to prevent the liquid from slopping over if carelessly poured into the spout. The plug K has a screw-thread cut upon its periphery at the lower end, and this is screwed into the neck or small end of the spout M. A gasket, R, is placed around the plug K above its threaded portion to make a tight joint between it and its seat at the lower end of the spout. A stem, 12, having an enlarged termination, 13, Fig. 2, at the top, projects upward from the plug K far enough to bring the upper surface of the stem at the top of the spout M.

A concave or saucer shaped disk L is secured in an inverted position to the top of the plug K by a screw, 3. On the under side of the disk L is a stud, 1, which projects into a slot, 14, in the enlarged top of the said plug when the disk L is secured in proper position thereon. The stud 1 prevents the disk L from being turned without at the same time turning the plug K. It will be found convenient to cast the disk L with projections upon its under side, as indicated at 11, for the purpose of having less bearing-surface upon the top of the plug K.

From the side of the spout M an arm, O, projects, to the end of which, at 2, is pivoted a latch, N.

When the disk L is properly attached to the plug K and the plug is screwed down upon its seat within the spout M the edge of the disk L will bear upon the inner end, 6, of the latch N and raise it into the position shown in the drawings. When arranged in connection with a stove, as shown therein, I place a catch, P, upon the side of the hanger B, in which the latch N will rest when the disk L is raised from its inner end.

The drawings illustrate a reservoir about three-quarters full of liquid and the plug screwed down to its seat within the filling-spout, thereby raising the latch N from the catch P, so that the reservoir may be turned as desired. By giving the reservoir a half-rotation the spout M will be in an opposite position, as shown in dotted lines Fig. 1—that is, hanging down below the reservoir instead of projecting above it—and also the ends s s' of the pipes G and I will be at the bottom of the reservoir below the liquid ready for operation, as indicated by $G' I'$ in dotted lines. The disk L also serves as a cover for the opening in the top of the spout M.

When the reservoir is hung behind the burners in the position illustrated, a hole should be made in the top of the stove immediately over the filling-spout M, when it is in the position shown, to facilitate filling.

The operation of unscrewing the plug K preparatory to filling the reservoir raises the disk L attached thereto and allows the latch N to drop into the catch P, and thereby hold the reservoir securely in place while being

filled, and the ends s s' of the pipes G I will be above the surface of the liquid, so that none can escape to the supply-pipe F while the reservoir is in that position. The operation of screwing the plug K to its seat again will raise the latch N from the catch P, and the reservoir is then free to be rotated, as above mentioned.

In order to show the position of the burners in connection with an oil-stove, I have illustrated a burner, E, attached to the pipe D, having a valve at its connection therewith at T, which is operated by the hand-wheel V.

When my improved supply-reservoir is used with a vapor-stove and the reservoir is turned to the position illustrated with the spout M in full lines in the drawings, the compressed air in the upper part thereof will soon force all of the liquid out of the pipes G, F, and D if the valve K is allowed to remain closed for a short time, and thus the flame will be extinguished.

For use with oil-stoves where a small pressure only is needed to discharge the oil, the reservoir may be economically made of sheet-iron, with its joints soldered, that being the means the least liable to allow the escape of the compressed air.

The hollow journals with their plates for attachment to the heads of the reservoir, the spout M, plug K, and disk L may be metal castings.

The pipes G and I may be continuous and integral with the pipes F and H, respectively, instead of being broken, as shown at 16 and 17, and the hollow journals of the reservoir throughout their length free to turn upon said pipes. With such construction the portions G and I of the pipes should be turned downward, as indicated in dotted lines at $G' I'$ in Fig. 1, so that the outlets s and s' would always be at the bottom of the reservoir. However, I have found it most advantageous to have the pipes G and I detached from the pipes F and H and secured by an air-tight joint to the hollow journals. The said journals may be cast with extensions into the reservoir in lieu of pipes G and I, but not so conveniently or economically.

In the drawings I have illustrated the reservoir as pivoted upon hollow journals at either end with their axes horizontal. This will be found a very convenient and advantageous arrangement when using the reservoir with an oil or vapor stove. Other locations and arrangements of the journals, however, will readily suggest themselves to manufacturers; but the essence and novelty of my invention is in having a liquid-receptacle pivoted upon hollow journals, through one of which compressed air can be admitted into the receptacle, and through the other of which the contained liquor can be discharged, and a filling-orifice provided with a closing-valve, and especially in having the internal openings from these three passages near together or upon the same side of the receptacle, so

that when it is adjusted into a position suitable for filling by turning it upon its pivots all of said openings within the receptacle will be above the level which the liquid will occupy, and when it is turned into a position to discharge the liquid all of said openings within the receptacle will be below the liquid and thus sealed therewith.

I claim—

10 1. A pivoted liquid-holding reservoir having an inlet or filling orifice, an outlet or discharge orifice, and an inlet for compressed air, all of which are located near together or upon the same side of the reservoir, which is
15 capable of adjustment by turning upon its pivots, whereby the said orifices will be raised above the level of the liquid contained in the reservoir when it is turned into proper position for filling, and said orifices will be lowered
20 beneath the liquid and sealed therewith when the reservoir is turned into position for discharging the same, substantially as described, and for the purpose specified.

25 2. A rotatory reservoir for holding and distributing liquids under pressure, provided with hollow journals having a pipe extending from each into the reservoir, to serve, respect-

ively, as an inlet for compressed air and an outlet for liquid, and both of said pipes terminating near the periphery of the reservoir upon the same side thereof as the filling-orifice. 30

3. A pivoted liquid-holding reservoir having a filling-orifice at one side and suitable pipes for the ingress of compressed air and the egress of the contained liquid, a valve for closing said filling-orifice, a plate connected with said valve, a suitable support for the reservoir having a catch thereon, and a latch pivoted to the reservoir and engaging the catch at one end when the valve is open and the plate at the other when the valve is closed, substantially as described. 35 40

4. A pivoted liquid-holding reservoir having a filling-orifice, an inlet for compressed air and an outlet for oil, all located upon the same side thereof, combined with a hydrocarbon-oil-burning stove, in the manner and for the purpose substantially as described. 45

WILLIAM H. THAYER.

Witnesses:

R. L. ROBERTS,
WALTER S. CAMPBELL.