

(No Model.)

2 Sheets—Sheet 1.

A. LE G. PEIRCE.

DRAW BRIDGE GATE.

No. 386,491.

Patented July 24, 1888.

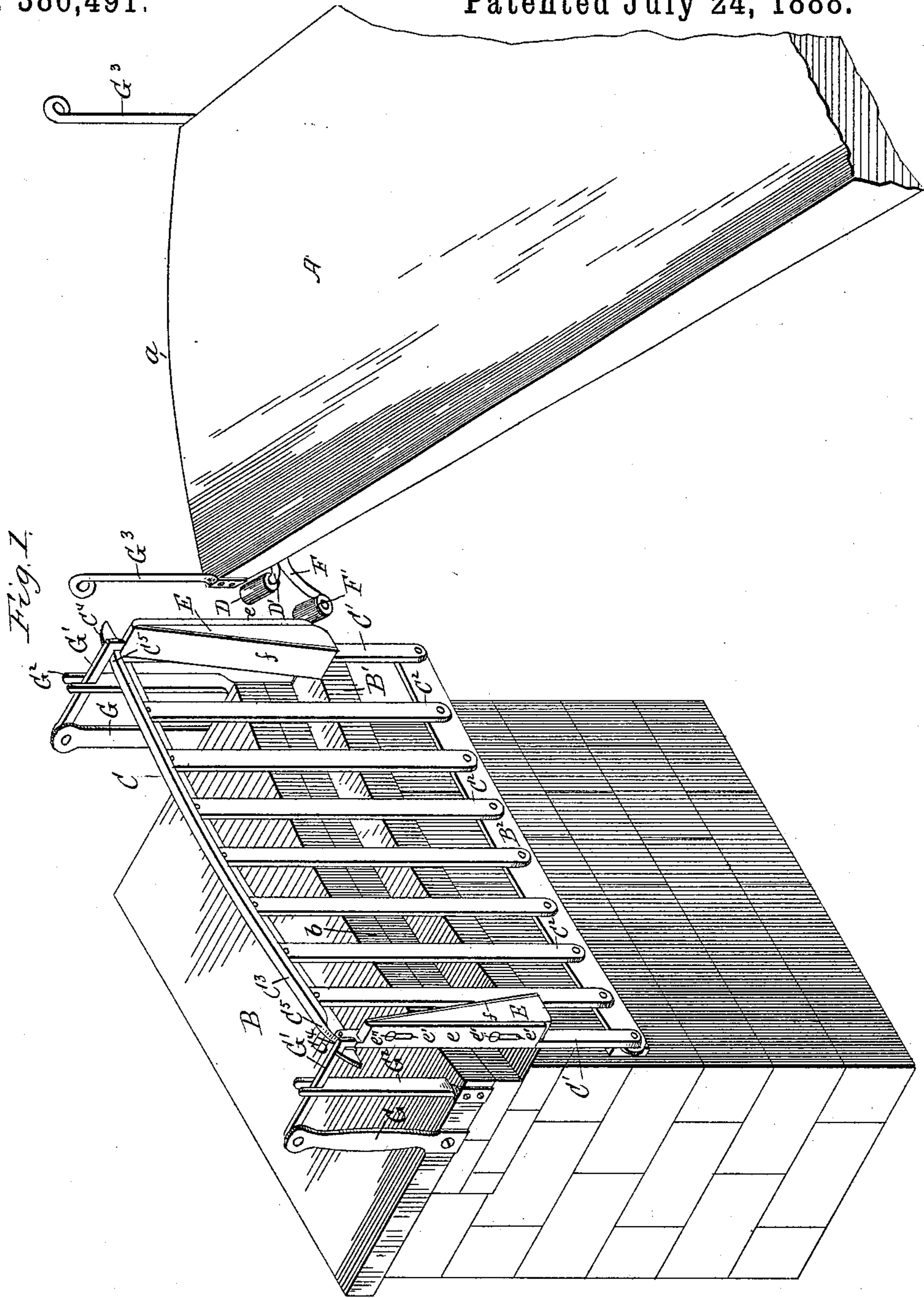

Witnesses:-  
 Jacob Ferris,  
 Calvin F. White.

Inventor:  
 A. Le Grand Peirce,  
 By Edmund D. Barry,  
 his attorney

A. LE G. PEIRCE.

DRAW BRIDGE GATE.

No. 386,491.

Patented July 24, 1888.

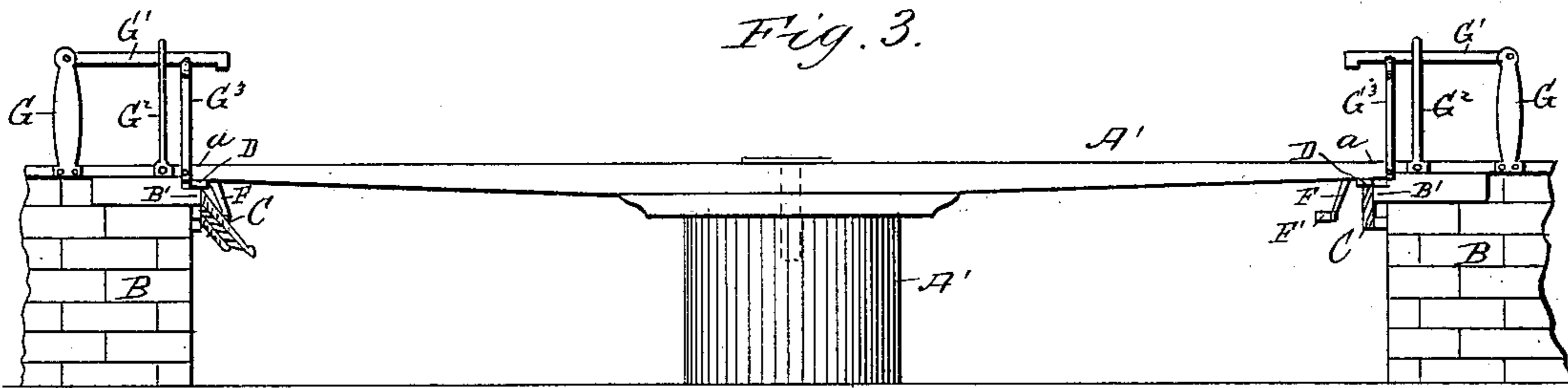
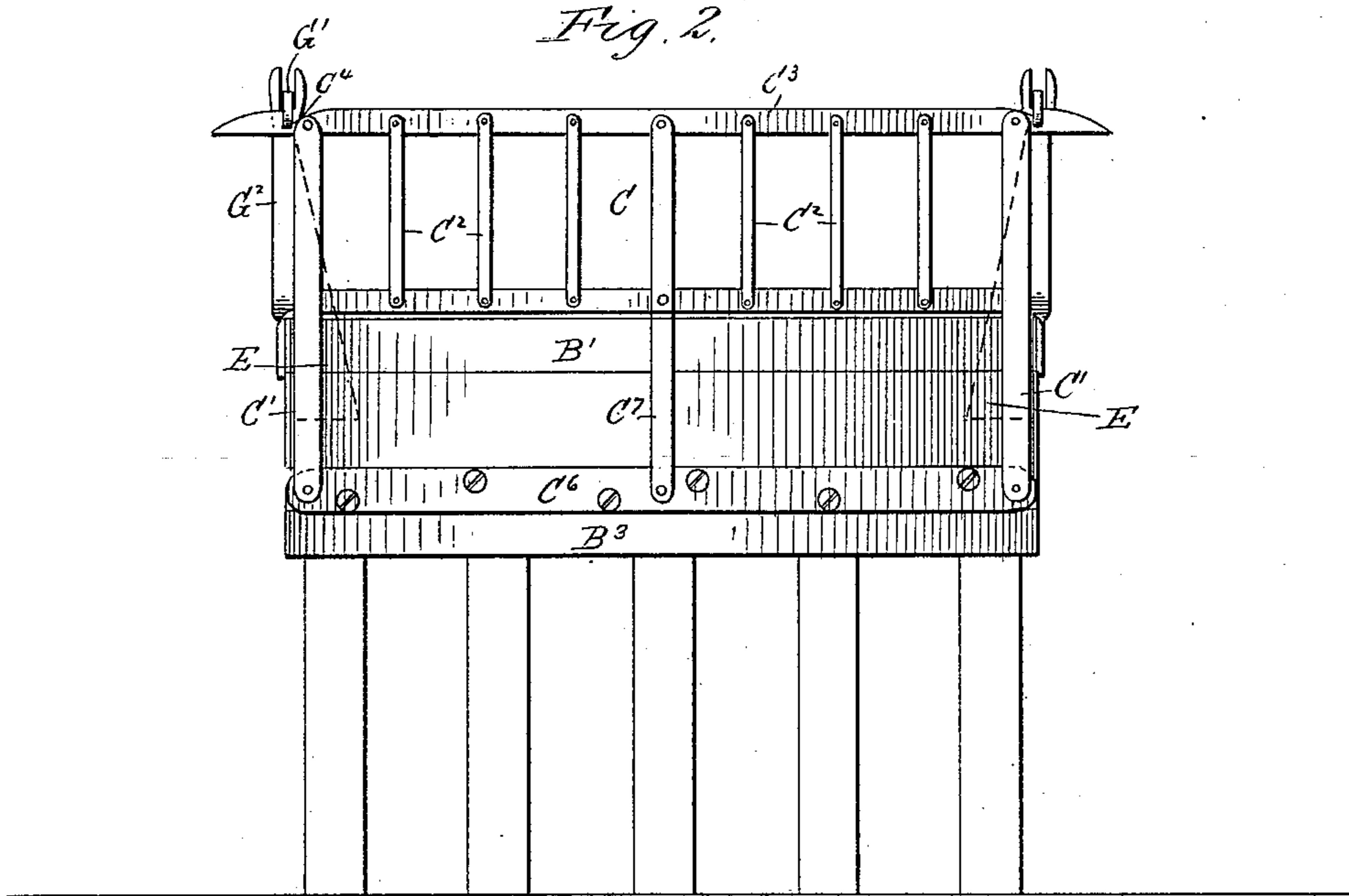

Witnesses:  
 Jacob Davis,  
 Edwin F. White.

Inventor:  
 A. Le Grand Peirce.  
 By Edmund D. Barry,  
 his attorney.

# UNITED STATES PATENT OFFICE.

ALMY LE GRAND PEIRCE, OF GRAND RAPIDS, MICHIGAN.

## DRAW-BRIDGE GATE.

SPECIFICATION forming part of Letters Patent No. 386,491, dated July 24, 1888.

Application filed March 12, 1888. Serial No. 266,938. (No model.)

*To all whom it may concern:*

Be it known that I, ALMY LE GRAND PEIRCE, a citizen of the United States, residing at Grand Rapids, in the county of Kent and State of Michigan, have invented certain new and useful Improvements in Draw-Bridge Gates; and I do hereby declare the following to be a full, clear, and exact description of the invention, such as will enable others skilled in the art to which it appertains to make and use the same.

My invention relates to draw-bridge gates which are automatically raised and lowered from the surfaces of roadways by the swinging of the draw spans or bridges. Many difficulties have hitherto arisen in making a practical gate for this purpose—as, for instance, when the gate is located in the joint between the end of the draw span or bridge and the abutment or pier a sufficient space is required between them to receive the gate bars and rails, and this space, even when the parts are closely fitted, is liable to become clogged and obstructed by snow, ice, and mud, and is also liable to impede and entrap both teams and foot-passengers; also, when the gates have been located to swing below the levels of roadways the outer ends of the draw spans or bridges have not been securely supported upon the piers or abutments, and the spans or bridges have been moved with difficulty, owing to various obstructions to the swinging of the outer ends thereof. To overcome these and other objections, I construct each face of the bridge abutment or pier with a projecting sill, located below the roadway-surface, for receiving and supporting the free end of the draw span or bridge when closed, and for bringing the surface of said draw span or bridge in the same plane with the surface of the roadway; also, I attach the vertical pivoted parallel bars forming the gate below the said projecting sill, whereby the top cross-rail of the gate, as well as the vertical pivoted bars, will be carried down below the surface of the said projecting sill, when the gate is closed, by contact with the swinging end of the draw span or bridge.

My invention consists in certain constructions and arrangements or combinations of parts for practically embodying the above-described features, and in certain other details of construction and combination of parts for

more easily moving and positively operating the gate in both directions and for locking and unlocking it when raised, as will hereinafter appear in the description, drawings, and claims.

In the accompanying drawings, wherein the same reference-letters indicate the same or corresponding parts, Figure 1 represents a perspective view of one end of a draw-span or swinging bridge and one of the piers or abutments with my improved gate applied thereto, the draw span or bridge being partly open and broken away and the gate being closed to travel; Fig. 2, a front elevation of a bridge pier or abutment, showing a modification of my improved gate when closed; and Fig. 3, a side elevation of a draw span or bridge, showing the pivotal supporting-pier in the center and the two end piers or abutments, the draw being open to travel and the gates lowered.

The draw span or bridge A is supported and swings upon a turn-table or pivoted supporting-pier, A', at its center, and each of its segmental ends *a* fits closely against a similar concaved inner face, *b*, of the pier or abutment B. Each of the piers or abutments has a projecting sill, B', located a sufficient distance below the surface of the roadway to solidly support the under side of the segmental end of the draw span or bridge and to bring its upper surface flush with the upper surface of the pier or abutment when the draw is closed.

The gate C is composed of a series of vertical end bars, C', and intermediate bars, C'', pivoted at their lower ends to a horizontal plate, B<sup>2</sup>, which is bolted upon the face of the pier or abutment B and below the projecting sill B'. Said bars are pivotally connected at their upper ends to a top rail, C<sup>3</sup>, which is held in horizontal position and moved in parallel planes above the surface of the roadway when the draw span or bridge is open and below the projecting sill B' when said draw-span or bridge is closed.

Rollers D are journaled upon brackets or arms D', which are securely bolted to the under side and near each corner of the draw span or bridge, the said rollers being thus held in position to press against the outer sides of wedge-shaped pieces or blocks E, which are formed with or secured upon the faces of the

end bars, C', of the gate, and thus push said gate out of the way and beneath the surface of the roadway when the draw is moved into line with the roadway and bridge piers or abutments. These rollers D, as the gates are lowered, pass over the top rails, C<sup>3</sup>. Arms F are also secured to the under side and near each corner of the draw span or bridge and carry rollers F', which are arranged below and slightly in advance of the rollers D, and pass under the wedge-shaped friction-blocks E; also, they are placed sufficiently in advance of said rollers D to permit the latter to strike the outer faces of said wedge-shaped friction-blocks E and press the gates down, said friction-blocks E then dropping upon said rollers F', by which they are then supported. As the bridge or draw span closes and the rollers F' advance, the latter traverse the under surfaces, f, of the friction-blocks, support the same, and thus prevent the gates from falling or shutting down suddenly, but permit them to be lowered smoothly and evenly.

When the draw span or bridge is closed and the gates are lowered, said draw span or bridge can only be opened in an opposite direction from that in which it was turned in closing, when the rollers F' will press against the under sides of the friction-blocks E and raise the end bars, C', together with the other parts of the gates, to their position above the roadway, and when that position is reached said rollers F' will pass clear of the friction-blocks E.

On the ends of the piers or abutments are secured uprights or posts G, to the upper ends of which are pivoted the rear ends of catches or latches G', which are guided and held midway of their length in the slotted upper ends of uprights or posts G<sup>2</sup>, which are also rigidly secured to the ends of said piers or abutments. The front ends of the latches G' are free to be raised and lowered, and are made of sufficient weight to engage with notches C<sup>4</sup>, formed in the ends of the top rails, C<sup>3</sup>, of the gates when the latter are in raised position. These notches are bounded on one side of each with an inclined or curved face, C<sup>5</sup>, which serves to raise the latch G' from the notch in the top rail over one side of the pier or abutment, while the other latch is raised from its notch by the rounded upper end of an upright or post, G<sup>3</sup>, these posts being secured at the corners, or one at each side of the ends of the draw span or bridge.

The outer contact-faces of the wedge shaped friction-blocks E are preferably formed of hardened-steel plates e, having longitudinal slots e', and are held securely upon said blocks by set-screws e'', which permit said plates to be shifted endwise upon said blocks when such is required for adjustment or to compensate for wear; also, the lower outer corners of these blocks are slightly rounded, so as to more easily pass over and clear the lower rollers, F', after the gate has been raised. The inner contact-faces of these blocks have secured thereto inclined friction-plates f, which may

have either flat or rounded surfaces over which the lower rollers, F', pass in closing or raising the gates.

Instead of having all of the gate-bars C' and C<sup>2</sup> extend down to the horizontal plate B<sup>2</sup>, which is secured upon the face of the pier or abutment, a lower cross rail or plate, C<sup>6</sup>, as shown in Fig. 2, is made to support the lower pivoted ends of the end bars, C', while a single intermediate bar, C<sup>7</sup>, extends down to the plate C<sup>6</sup> and serves to brace and pivot the middle portion of the gate. A lower sill, B<sup>3</sup>, which is also shown in Fig. 2, serves as a walk or platform for workmen in making repairs.

In operation, when the draw is swung in one direction to open the bridge and lower the gates, it is turned in the other direction to close the former and raise the latter above the surface of said roadway or bridge and close the same.

The employment of the projecting arms and rollers upon the corners of the draw span or bridge for raising and lowering the gates constitutes an important feature of my invention for the operation of the gates herein shown and described as used in connection with a swinging draw span or bridge; but the devices for locking my improved construction of gate may be varied without departing from the nature of my invention.

A bridge-gate of my improved construction, as will be obvious, is simple, strong or durable, not liable to get out of order, and easily operated, and, besides, affords ample security against the accidents occasionally occurring at draw spans or bridges.

I am aware that it is not broadly new to automatically raise and lower gates above and below the surfaces of roadways and bridges by the swinging of the draw spans or bridges, and I do not claim the same as my invention; but,

Having thus fully described the construction, arrangement, operation, and advantages of the several parts of my invention, what I claim as new is--

1. The combination, with the pier or abutment, of the latch-posts, the latches pivotally supported thereon, the slotted uprights, the folding gate pivotally secured to said pier or abutment, and a swinging draw span or bridge provided with posts at its corners for lifting said latches when the gate is to be opened, substantially as described.

2. The combination of a pier or an abutment with a folding gate provided with vertical pivoted end bars, C', top rail, C<sup>3</sup>, and friction-blocks E, secured to and projecting from said end bars, and a draw span or bridge, A, provided with arms and rollers, which are supported upon the corners thereof, for engaging with said friction-blocks and opening and closing said gate, substantially as described.

3. The combination of a pier or an abutment with a folding gate provided with vertical pivoted end bars, C', top rail, C<sup>3</sup>, and friction-blocks E, secured to and projecting from said end bars, and provided on their inner

faces with inclined friction-plates *f* and on their  
outer faces with adjustable friction-plates *e*,  
and a draw span or bridge, A, provided with  
arms and friction-rollers which are supported  
5 upon its corners and arranged to engage with  
said friction blocks and plates and to thus open  
and close said gate, substantially as described.

4. The combination of a pier or an abut-  
ment, a folding gate consisting of vertical bars  
10 and intermediate bars, which are pivoted at  
their upper and lower ends, a horizontal plate  
and a top rail having notches near its ends  
with pivoted latches, and a swinging draw span  
or bridge provided with vertical posts at its  
15 corners having rounded upper ends, substan-  
tially as and for the purpose described.

5. A folding gate for draw-bridges, com-  
prising a horizontal stationary bottom plate,  
a movable top rail, and vertical bars pivoted  
at their ends to said bottom plate and top rail, 20  
in combination with latches for holding said  
gate in raised position and devices for raising  
and lowering the same, substantially as de-  
scribed.

In testimony whereof I affix my signature in 25  
presence of two witnesses.

ALMY LE GRAND PEIRCE.

Witnesses:

CHAS. M. WILSON,  
JACOB FERRIS.