

(No Model.)

E. BERLINER.
GRAMOPHONE.

No. 372,786.

Patented Nov. 8, 1887.

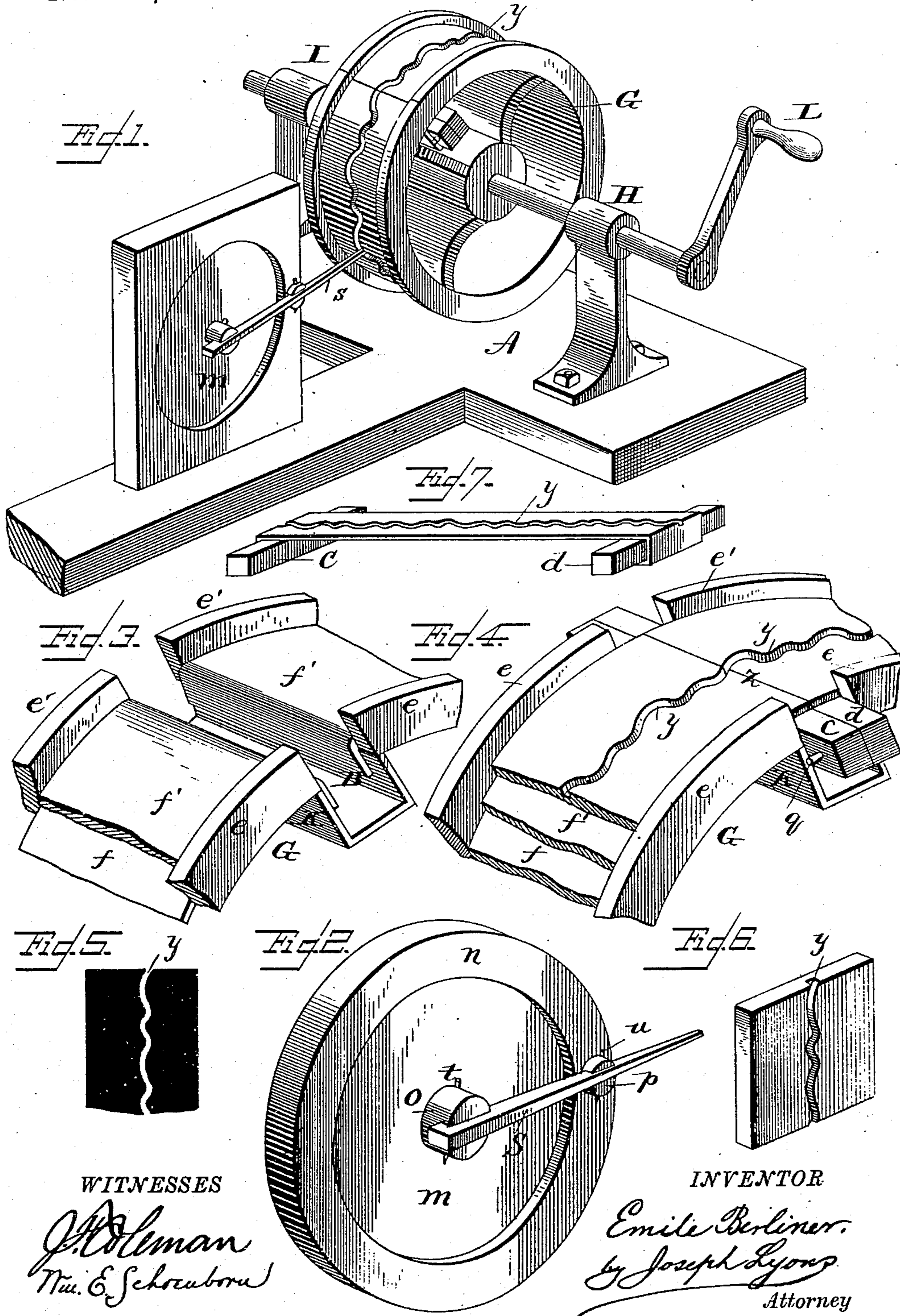

WITNESSES
J. Adelman
Thos. E. Schaubert

INVENTOR
Emile Berliner.
by Joseph Lyons
Attorney

UNITED STATES PATENT OFFICE.

EMILE BERLINER, OF WASHINGTON, DISTRICT OF COLUMBIA.

GRAMOPHONE.

SPECIFICATION forming part of Letters Patent No. 372,786, dated November 8, 1887.

Original application filed May 4, 1887, Serial No. 237,000. Divided and this application filed September 26, 1887. Serial No. 250,721.
(No model.)

To all whom it may concern:

Be it known that I, EMILE BERLINER, a citizen of the United States, residing at Washington, in the District of Columbia, have invented certain new and useful Improvements in Gramophones, of which the following is a specification.

This invention has reference to a novel method of and apparatus for recording and reproducing all kinds of sounds, including spoken words, and is designed to overcome the defects inherent in that art as now practiced and in the apparatus used therefor.

By the ordinary method of recording spoken words or other sounds for reproduction it is attempted to cause a stylus attached to a vibratory diaphragm to indent a traveling sheet of tin-foil or other like substance to a depth varying in accordance with the amplitudes of the sound-waves to be recorded. This attempt is necessarily more or less ineffective, for the reason that the force of a diaphragm vibrating under the impact of sound-waves is very weak, and that in the act of overcoming the resistance of the tin-foil or other material the vibrations of the diaphragm are not only weakened, but are also modified. Thus while the record contains as many undulations as the sounds which produce it, and in the same order of succession, the character of the recorded undulations is more or less different from those of the sounds uttered against the diaphragm. There is, then, a true record of the pitch, but a distorted record of the quality of the sounds obtained. The simple statement that the material upon which the record is made resists the movement of the diaphragm is not sufficient to explain the distortion of the character of the undulations, for if that resistance were uniform, or even proportional to the displacement of the stylus, the record would be simply weakened, but not distorted; but it is a fact that the resistance of any material to indentation increases faster than the depth of indentation, so that a vibration of greater amplitude of the stylus meets with a disproportionately greater resistance than a vibration of smaller amplitude. For this reason loud sounds are even less accurately recorded than faint sounds, and the individual voice of a loud speaker recorded and then reproduced by the phonograph cannot be recognized. With a view of

overcoming this defect it has been attempted to engrave instead of indent a record of the vibrations of the diaphragm by employing a stylus shaped and operating like a chisel upon a suitably-prepared surface; but even in this case the disturbing causes above referred to are still present. In addition to this, if in the apparatus of the phonograph or graphophone type it is attempted to avoid the disturbing influence of the increase of resistance of the record-surface with the depth of indentation or cut as much as possible by primarily adjusting the stylus so as to touch the record-surface only lightly, then another disturbing influence is brought into existence by the fact that with such adjustment, when the diaphragm moves outwardly, the stylus will leave the record-surface entirely, so that part of each vibration will not be recorded at all. This is more particularly the case when loud sounds are recorded, and it manifests itself in the reproduction, which then yields quite unintelligible sounds.

It is the object of my invention to overcome these difficulties by recording spoken words or other sounds without perceptible friction between the recording-surface and the recording-stylus, and by maintaining the unavoidable friction uniform for all vibrations of the diaphragm. The record thus obtained, almost frictionless, I copy in a solid resisting material by any of the methods hereinafter described, and I employ such copy of the original record for the reproduction of the recorded sounds.

Instead of moving the recording-stylus at right angles to and against the record-surface, I cause the same to move under the influence of sound-waves parallel with and barely in contact with such surface, which latter is covered with a layer of any material that offers a minimum resistance to the action of a stylus operating to displace the same, all substantially in the manner of the well-known phonautograph by Leon Scott. All this will more fully appear from the following detailed description, in which reference is made to the accompanying drawings, which illustrate one of the numerous forms which my improved apparatus may assume, and in which—

Figure 1 is a perspective view of my recording and reproducing apparatus; Fig. 2, a like

view of the recording and reproducing diaphragm with its stylus; Fig. 3, a similar view of a portion of the support for the record-surface; Fig. 4, the same view with the record-surface applied; Fig. 5, a plan view of a phonautographic record; Fig. 6, a perspective of a phonautographic record copied in solid resisting material; and Fig. 7, the copied record mounted, ready for application to the support.

The general arrangement of the parts is best illustrated in Fig. 1, in which a T-shaped base-plate, A, is shown, upon which two standards, H I, serving as journal-bearings for the shaft of drum G, are mounted. The drum G may be constructed with flanges $e e'$, which project beyond the cylinder-surface f , and from the edges of a gap, B, left upon the cylinder-surface extend the side walls of box K, as shown. A thin layer of felt or other yielding elastic substance is placed upon the cylinder-surface and is bent over the edges of the gap and secured to the side walls of the box K. This layer of elastic material is designed to serve as the support for the record-surface both in recording and reproducing.

For recording I employ a thin strip of paper, parchment, metal, or any other suitable substance, which is secured at both ends to bars $c d$, in the manner shown in Fig. 7, with reference to a copy of a record, and is then placed upon the elastic support f' , with the bars $c d$ entering into but projecting at both ends beyond the box K, as illustrated in Figs. 1 and 4, with reference to an engraved copy of a record. Bolts g , passing through the projecting ends of bars $c d$, are employed to draw the record-strip tightly about the drum, and the length of the strip is such that the ends of the same meet as nearly as practicable upon a straight line, z . The record-sheet is then prepared to receive the record by covering its surface with a thin layer of any substance which is easily removed by the action of the recording-stylus. I may use lamp-black, which is deposited by placing a smoky flame under the record-strip and by slowly turning the drum until all parts of the strip are covered with the deposit. It is well known that a layer of lamp-black thus deposited, while it adheres well to the surface of a solid body, is nevertheless easily removed from the same. It requires only an exceedingly small force to draw a plainly-visible line upon such surface, owing to the fact that the spicules of carbon of which lamp-black is composed are only loosely superimposed upon each other, and are exceedingly light. All this has long since been recognized and utilized in the production of phonautographic records, and I take advantage of these facts in my improved method of recording and reproducing sounds.

The diaphragm m is mounted in a frame, n , with its plane at right angles to the axis of drum G. A post, O, is fixed to the center of the diaphragm, and a slot in said post receives one end of stylus S, which is pivoted in the

post by a pin, t . The stylus extends over and beyond the frame, with its free end barely in contact with the record-surface, and is also pivotally supported in a slot in a post, p , secured to the frame by means of a pin, u , as shown in Figs. 1 and 2. It will now be seen that the stylus is in effect a lever having its fulcrum in the pin u , and that its free end can only move in lines practically parallel to the record-surface. If it is now desired to produce a record of sounds the drum is slowly and uniformly rotated by means of crank I, or by any other suitable means, and sounds are uttered or directed against the diaphragm. Under the impact of the sound-waves the diaphragm is set into vibrations, whereby the free end of the stylus is also caused to vibrate to the right and left of its normal position, removing at the same time an undulating line, y , of lamp-black from the record-surface, as indicated, greatly exaggerated, in Fig. 5. Since in this operation the stylus only penetrates a uniform layer of loosely-heaped carbon spicules and barely touches the record-surface, it is clear that the slight friction at the free end of the stylus will be uniform, whatever be the amplitude of vibration. Consequently the vibrations of the diaphragm will not be modified or changed by the reaction upon the same of a sensible and varying resistance, as is the case in all other mechanical sound-recorders.

Having thus obtained an accurate phonautographic record, the same may be fixed by applying a thin solution of varnish of any kind which dries very rapidly and which does not obliterate or change the record.

If in this process the deposit of lamp-black be made thick enough, the line drawn by the stylus would represent a groove of even depth, preserving all the characteristics of the sounds which produced it and which may be handled and touched with impunity. The latter is then removed from the drum and may be preserved any length of time without danger of its being disfigured. This record I then copy in solid resisting material, preferably metal, either by the purely mechanical process of engraving, or by chemical deposition, or by photo-engraving. I prefer the last-named process, which enables me to produce the most accurate copy of the original record in copper, nickel, or any other metal without in any way or manner affecting the original record. The copy thus obtained, which may be multiplied to any desired extent, is a grooved wave-line upon a strip or sheet of copper or other metal, as shown in Figs. 1, 4, 6, and 7, and for the reproduction of the recorded sounds it has the advantage over the ordinary records in tin-foil, wax, &c., that it is not sensibly attacked by the reproducing-stylus, and will stand an indefinite number of reproductions without the slightest variation in the accuracy and loudness of the reproduced sounds.

The copied record is fixed at both ends to the bars $c d$, as shown in Fig. 7, and is placed

upon the elastic support f' upon the drum in the same manner as has been described with reference to the original record-strip, and as is illustrated in Figs. 1 and 4. Care must be taken that the two ends of the undulatory groove y meet exactly, as will be readily understood. This condition of the apparatus is shown in Fig. 1 with the engraven record upon the drum and the free end of the stylus entering the undulatory groove. If, now, the drum is rotated with uniform speed, the end of the stylus will be forced to follow the undulations of the groove y , and the diaphragm will be vibrated positively in both directions in strict accordance therewith, and will therefore reproduce the exact sounds which originally produced the record. This peculiarity of positive vibratory movement in both directions of the diaphragm is a feature which also distinguishes my method and my apparatus from others heretofore used.

In the phonograph and graphophone the end of the reproducing-stylus which bears upon the indented or engraved record has a vertical upward and downward movement. It is forced upwardly in a positive manner by riding over the elevated portion of the record, but its downward movement is effected solely by the elastic force of the diaphragm, which latter is always under tension. In my improved apparatus the stylus travels in a groove of even depth and is moved positively in both directions. It does not depend upon the elasticity of the diaphragm for its movement in one direction. This I consider to be an advantage, since by this method the whole movement of the diaphragm is positively controlled by the record, and is not affected or modified by the physical conditions of the diaphragm, which conditions necessarily vary from time to time and constitute some of the causes of imperfect reproduction of recorded sounds.

In practicing my method of recording and producing sounds I am not limited to the use of the identical apparatus herein shown and described. This apparatus may be varied indefinitely without seriously impairing its utility for the purposes in view. Thus it is not absolutely necessary that a diaphragm should be used for receiving the impact of sound-waves in recording and for remitting sounds in reproducing. Any sonorous body of whatever shape and material may be used in lieu of a diaphragm proper. The recording-surface need not be mounted upon a drum, but may be supported in any suitable manner upon a support of any description which is adapted to move the same under the stylus evenly and with approximately uniform speed. Nor do

I confine myself to the use of lamp-black as a substratum for the phonautographic record, although I have found this substance to yield excellent results. Any other substance which adheres well to the support and may at the same time be removed from the same with a minimum force may be employed.

While I have found the process of photo-engraving to yield admirable copies of the phonautographic record, I do not mean to confine myself to this process to the exclusion of other processes for copying and multiplying the original record in solid resisting material; and it will be readily understood that the details of construction of my apparatus and the manipulations of the same may be greatly changed without departing from the fundamental idea of my invention.

I do not herein claim the apparatus shown and described, either generically or specifically, as a whole or in part, since the same forms the subject of another application for patent previously filed by me and of which this is a division.

What I do claim, and desire to secure by Letters Patent, is—

1. The method or process of recording and reproducing spoken words and other sounds, which consists in first drawing an undulatory line of even depth in a traveling layer of non-resisting material by and in accordance with sound-vibrations, then producing the record thus obtained in solid resisting material, and finally imparting vibrations to a sonorous body by and in accordance with the resisting record, substantially as described.

2. The method or process of reproducing sounds recorded phonautographically, which consists in copying the phonautographic record in solid resisting material, and then imparting vibrations to a sonorous body by and in accordance with the copy of the original record, substantially as described.

3. The method or process of reproducing sounds recorded phonautographically, which consists in copying the phonautographic record in solid resisting material by the process of photo-engraving, and then imparting positive to-and-fro movements to a sonorous body by and in accordance with the copy of the original record, substantially as described.

In testimony whereof I have signed my name to this specification in the presence of two subscribing witnesses.

EMILE BERLINER.

Witnesses:

JULIUS SOLGER,
JACOB G. COHEN.