

(No Model.)

W. STANLEY, Jr.

INDUCTION COIL.

No. 349,611.

Patented Sept. 21, 1886.

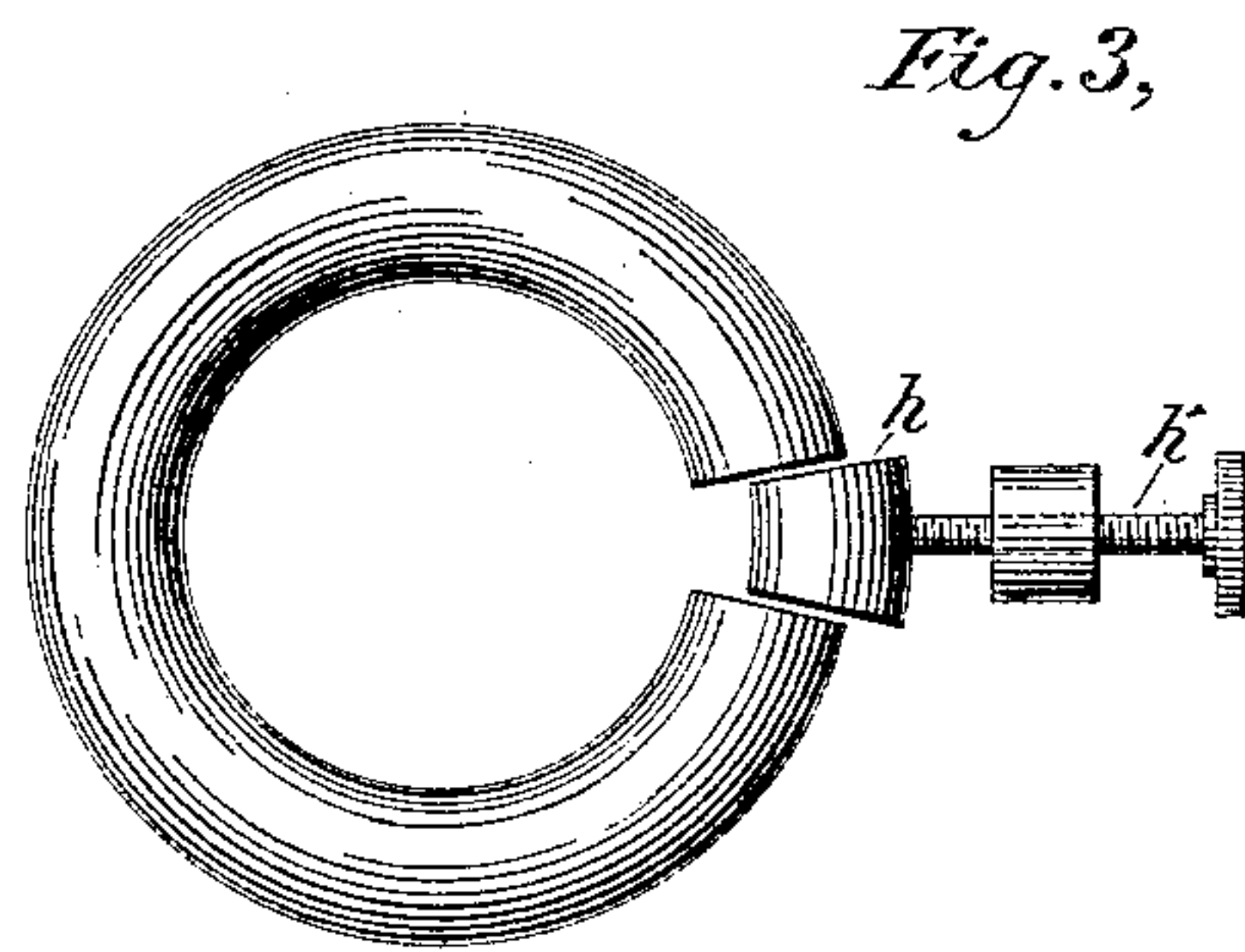
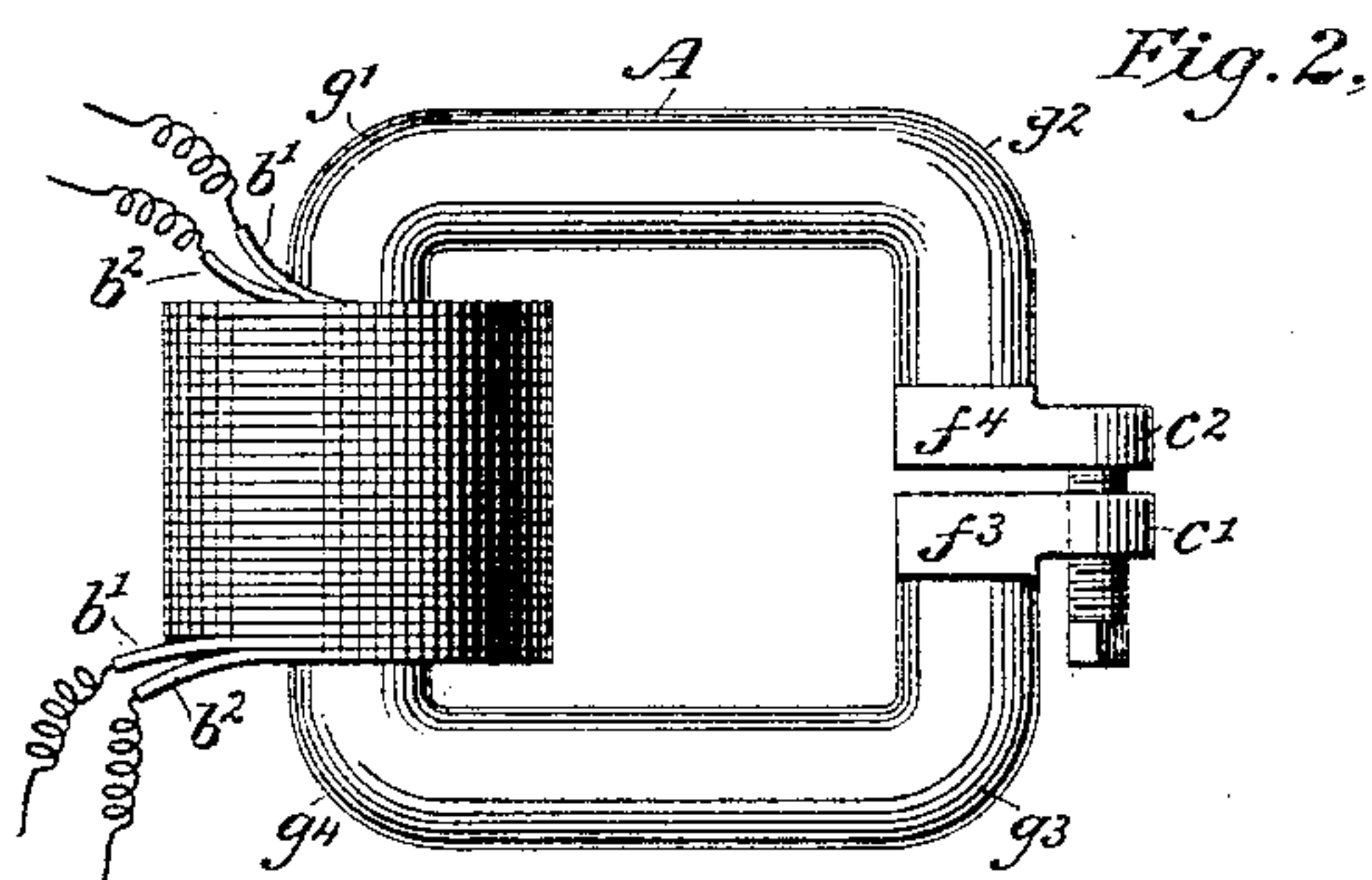
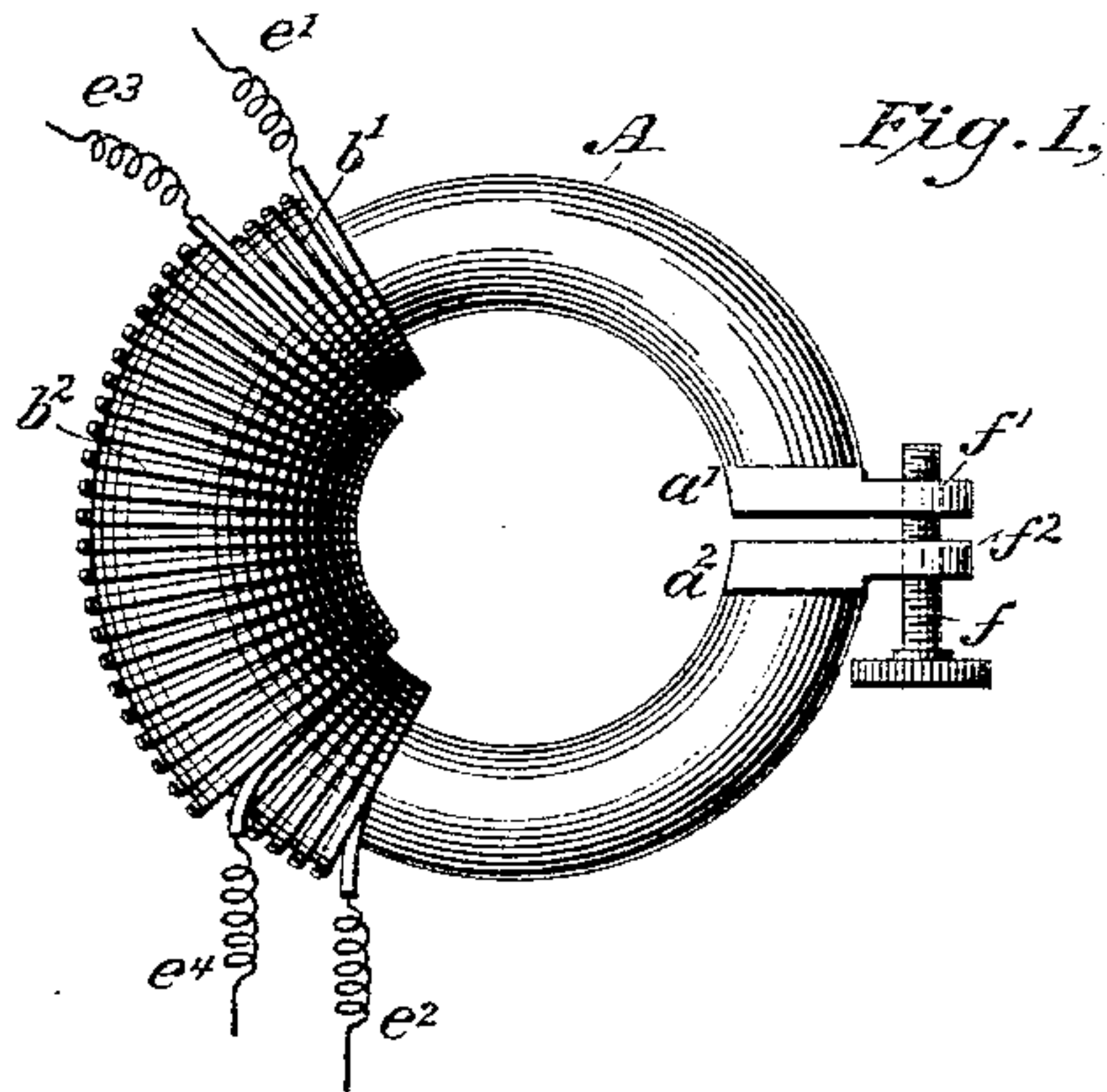

Witnesses

Geo. W. Brock
Carrie O. Ashley

Inventor

William Stanley Jr.

By his Attorneys

Pope & Edgcomb

UNITED STATES PATENT OFFICE.

WILLIAM STANLEY, JR., OF GREAT BARRINGTON, MASSACHUSETTS, ASSIGNOR TO GEORGE WESTINGHOUSE, JR., OF PITTSBURG, PA.

INDUCTION-COIL.

SPECIFICATION forming part of Letters Patent No. 349,611, dated September 21, 1886.

Application filed October 23, 1885. Serial No. 180,737. (No model.)

To all whom it may concern:

Be it known that I, WILLIAM STANLEY, JR., a citizen of the United States, residing in Great Barrington, in the county of Berkshire and State of Massachusetts, have invented certain new and useful Improvements in Induction-Coils, of which the following is a specification.

My invention relates to the construction of induction-coils or inductoriums.

The object of the invention is to so construct an induction-coil that from a given weight of metal in the primary and secondary conductors and in the core a higher electro-motive force will be developed than in the ordinary forms, and the consequent efficiency of electric conversion per unit of weight of apparatus will be increased; and a further object of the invention is to provide convenient means for modifying the electro-motive force developed in the secondary coils.

The invention consists in giving to the core of the coils an annular form, the ends confronting each other, but separated by a small space. The extent of this separation is rendered variable by means of an adjusting-screw of non-magnetic material acting upon the respective ends, so as to cause them to approximate or recede from each other, as desired.

A special application of the invention is in the case of inductoriums employed in certain systems of electrical distribution for incandescent electrical lighting, in which intermittent or alternating electric currents are transmitted through the primary circuits of the coils, the lamps being placed in the secondary circuits. The conversion of electro-motive force by means of such coils is not only rendered more economical and practical by this invention, but by varying the distance between the ends of the core, and thus varying the electro-motive force of the secondary, the intensity of the lights may be easily and conveniently modified, and the brilliancy of illumination in different lamps may thus be rendered uniform. The primary and secondary coils may be superposed one upon the other, or they may be wound parallel with each other, or their different layers may alternate, according to circumstances.

In the accompanying drawings, Figure 1 is

an elevation, partly in section, of an induction-coil embodying the features of my invention. Figs. 2 and 3 show a modification of the same.

Referring to the drawings, A represents an annular core having its ends at a' a'' confronting each other. The core is formed, as usual, of soft iron, and may consist either of a single piece of metal or of a bundle of separate wires or strips, as found desirable. A primary coil, b' , encircles this core, the terminals of which are shown at e' and e'' . The secondary coil b'' is shown in the drawings as superposed upon and exterior to the primary coil; but its situation in reference thereto may be varied, as already stated. Its terminals are shown at e' and e'' . The ends of the core may be left free; but preferably they are provided with non-magnetic projections f' f'' , through suitable holes in which extends a two-way adjusting-screw, f . By means of this screw the proximity of the two confronting ends of the core may be readily varied.

In Fig. 2 a slightly-modified form of coil is shown, its core being somewhat rectangular in form, having curved angles g' , g'' , g''' , and g'''' . The primary coil b' is shown in this instance as being wound with alternate layers of the secondary coil b'' . The confronting ends of the core are provided with non-magnetic pieces f''' and f'''' , and the adjusting-screw f extends through one piece, e' , and bears against the other, e'' , the core being constructed so that its ends tend to spring toward each other, while the screw serves to separate them, as required.

Instead of adjusting the ends of the core toward and away from each other, a movable soft-iron piece, h , may be employed, as shown in Fig. 3. This may be moved away from or into greater proximity to the poles by means of a screw, h' .

I claim as my invention—

1. An induction-coil or inductorium consisting of parallel primary and secondary conductors, an iron core within the same, forming an approximately-closed magnetic circuit, and means for modifying or varying the magnetic resistance of the closed magnetic circuit.

2. An induction-coil or inductorium provided with a core having its ends confronting, means for varying the distance of said ends

from each other, and primary and secondary coils upon said core.

3. In combination with an induction-coil having the ends of its core confronting each other, a non-magnetic device for adjusting the distance of said ends from each other.

In testimony whereof I have hereunto sub-

scribed my name this 19th day of October, A. D. 1885.

WILLIAM STANLEY, JR.

Witnesses:

DANL. W. EDGECOMB,
CHARLES A. TERRY.