

(No Model.)

A. BURGESS.

2 Sheets—Sheet 1.

MAGAZINE FIRE ARM.

No. 303,262.

Patented Aug. 12, 1884.

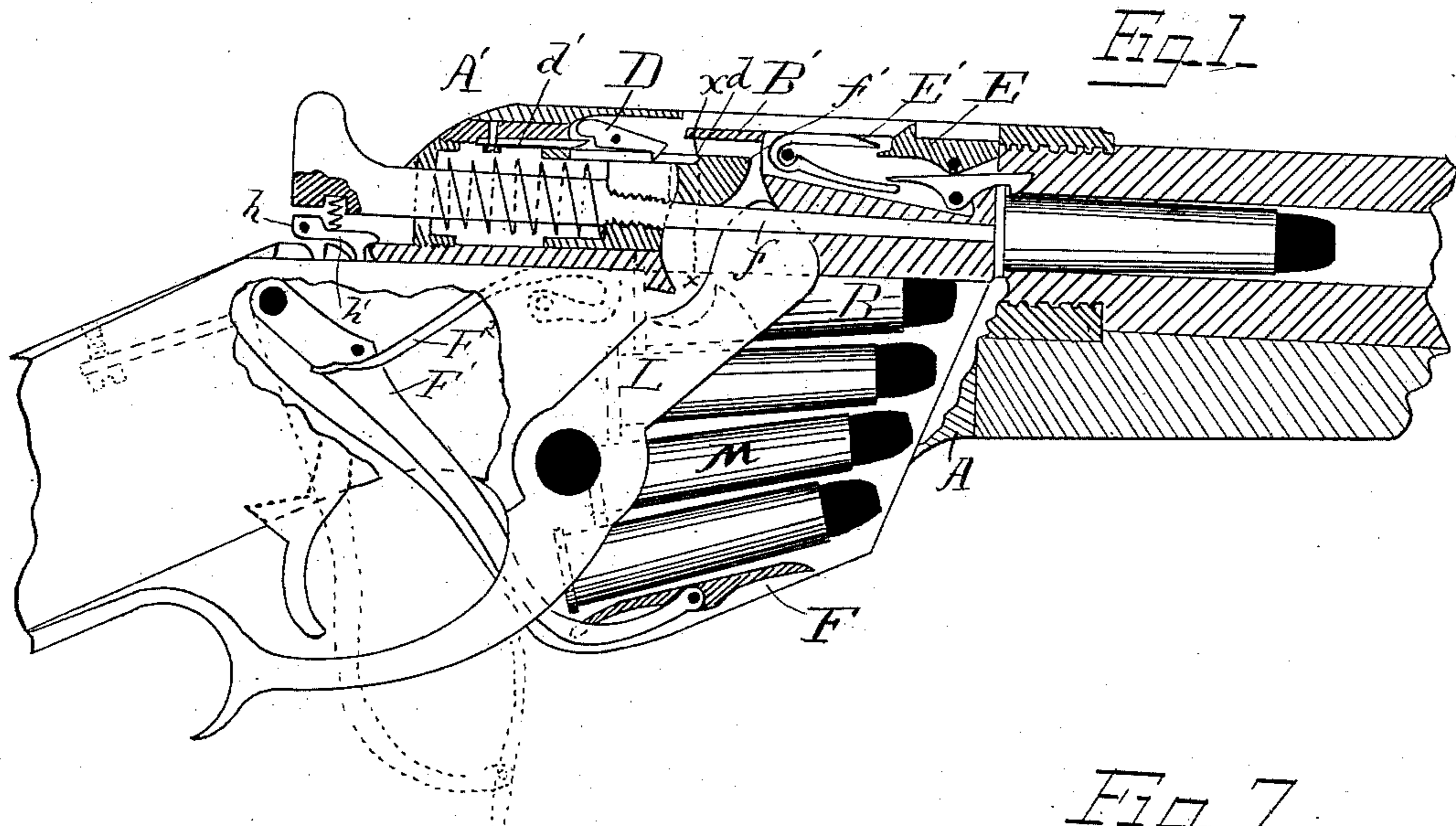

Fig. 1

Fig. 4

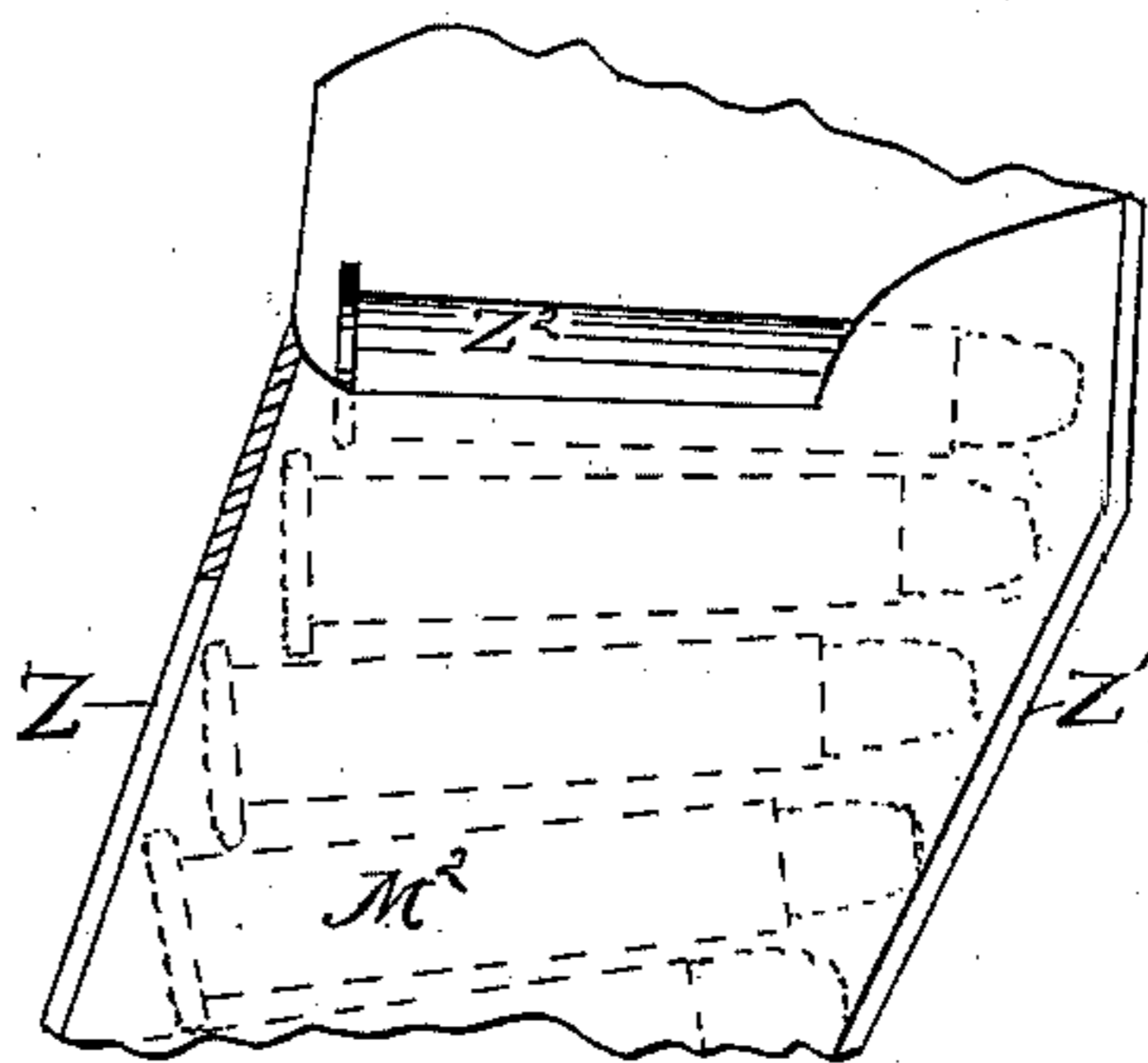
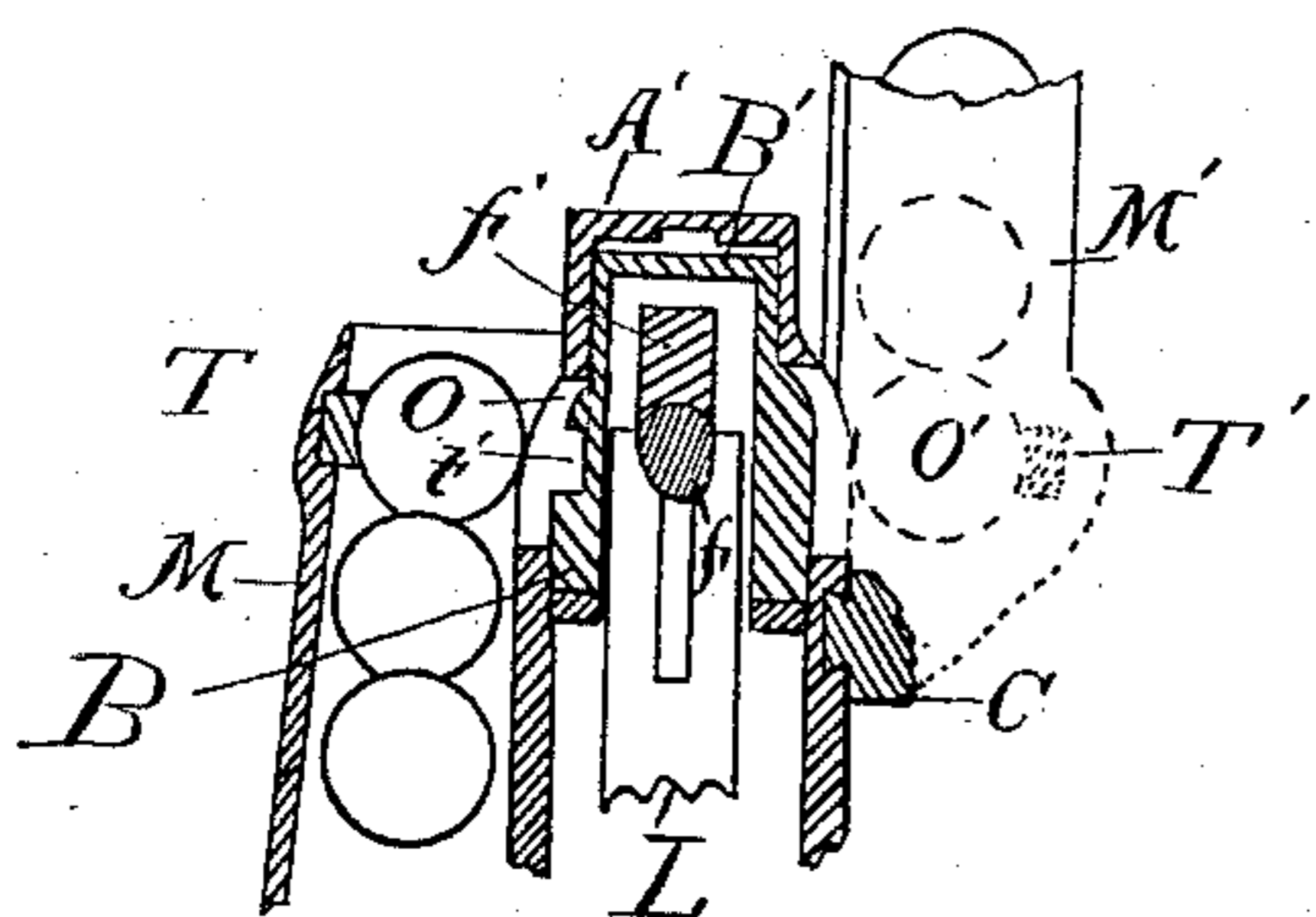
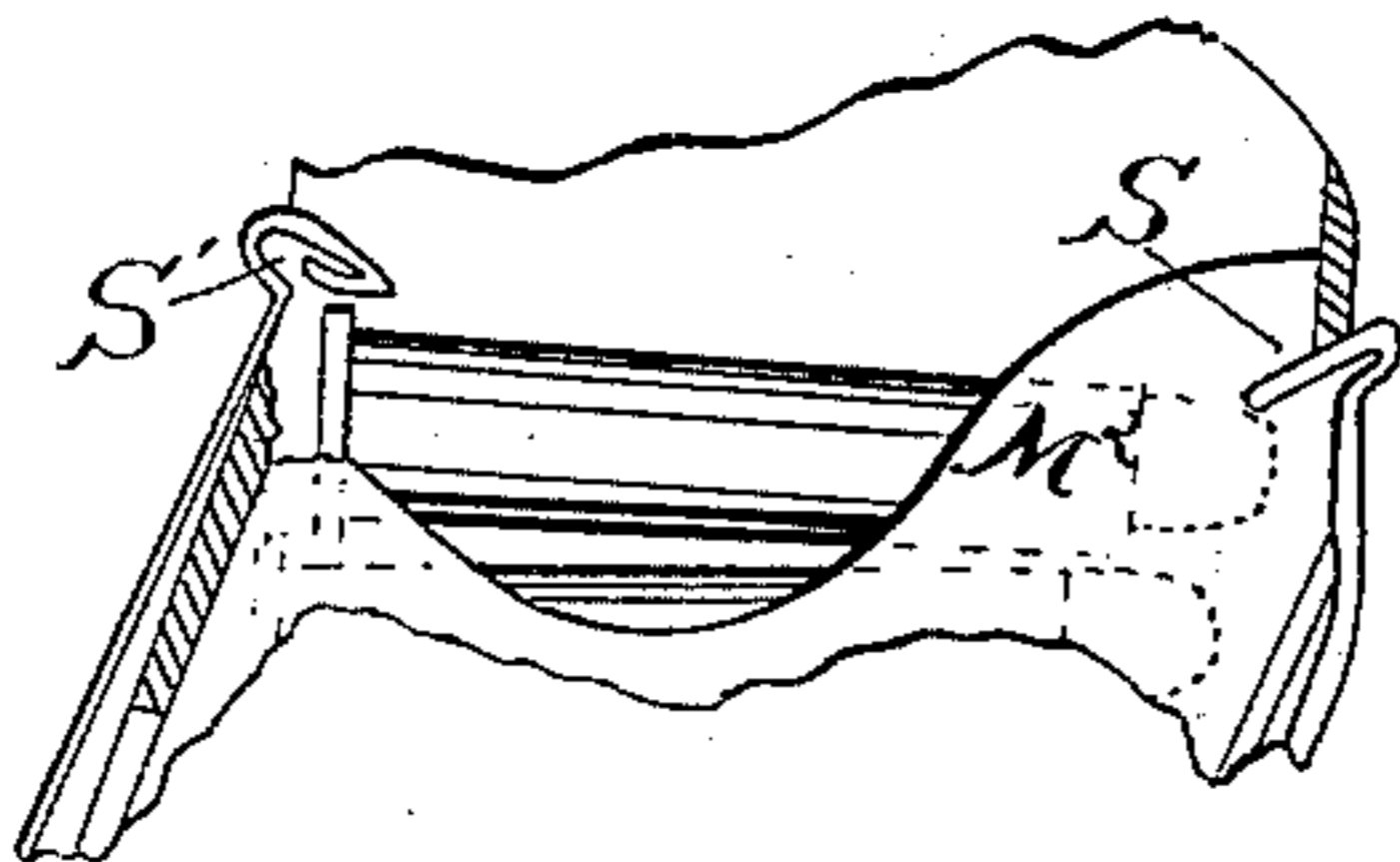

Fig. 8



Witnesses

Philip Hawley
G. W. Brown

Inventor

Andrew Burgess
per Wallace & Bartlett
His atty.

(No Model.)

2 Sheets—Sheet 2.

A. BURGESS.

MAGAZINE FIRE ARM.

No. 303,262.

Patented Aug. 12, 1884.

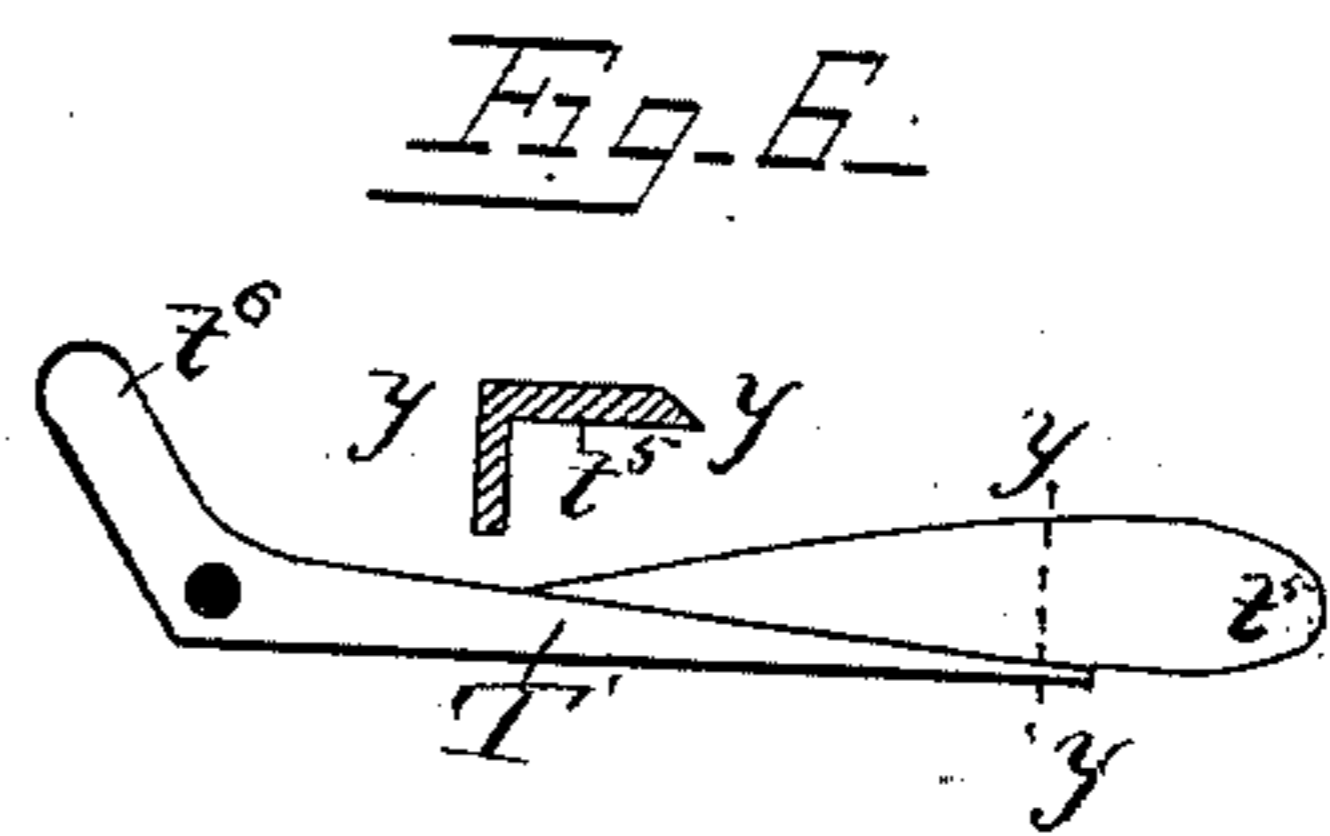
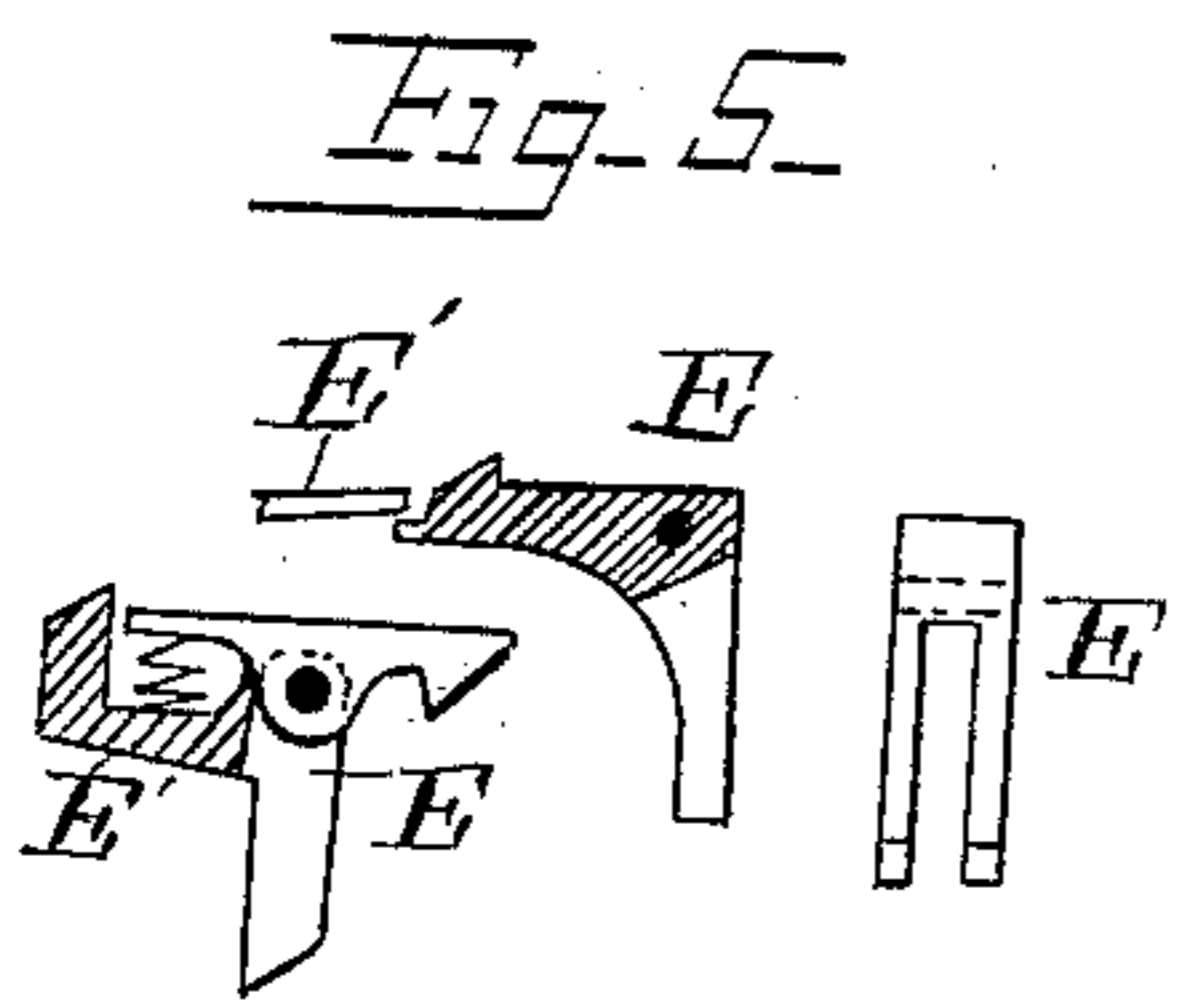
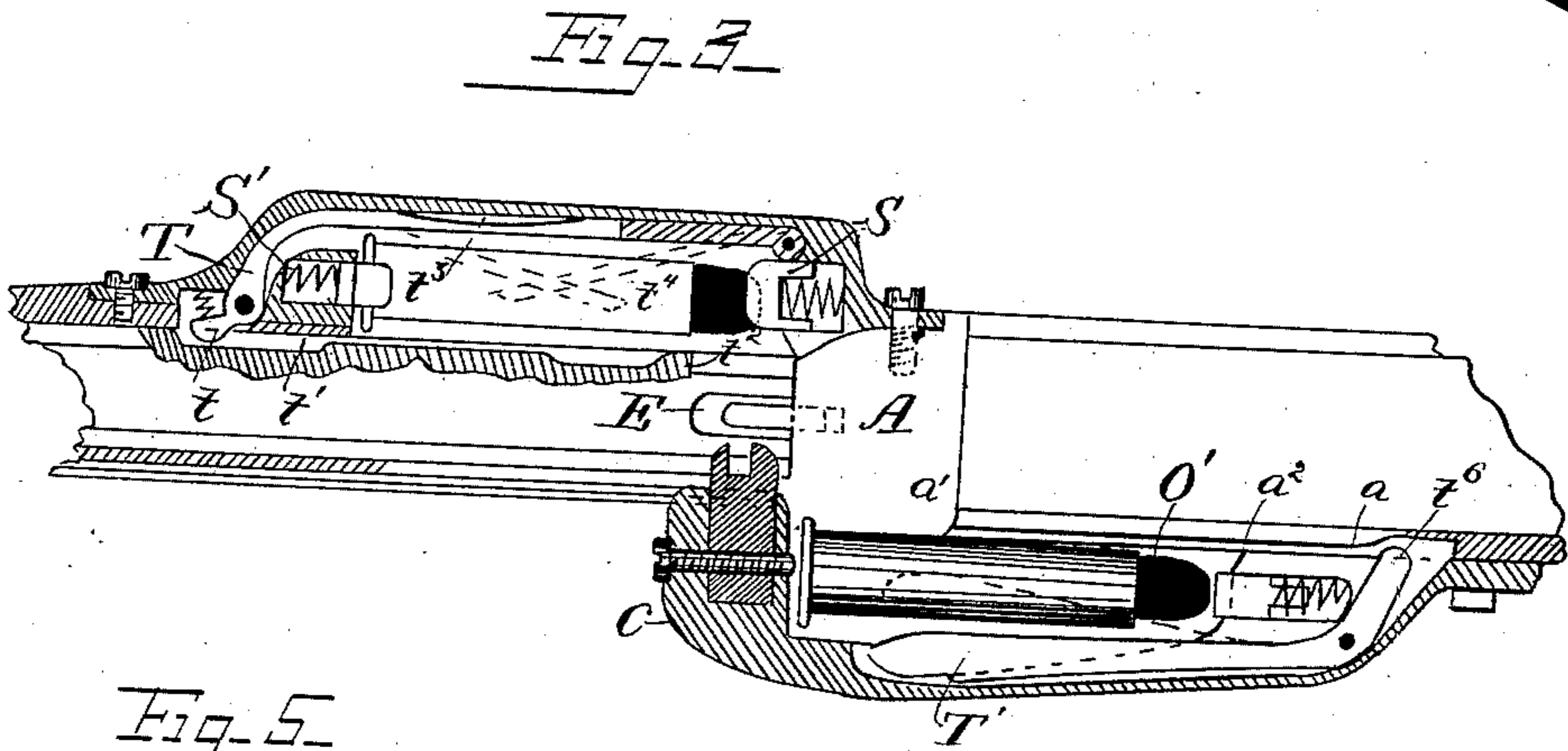
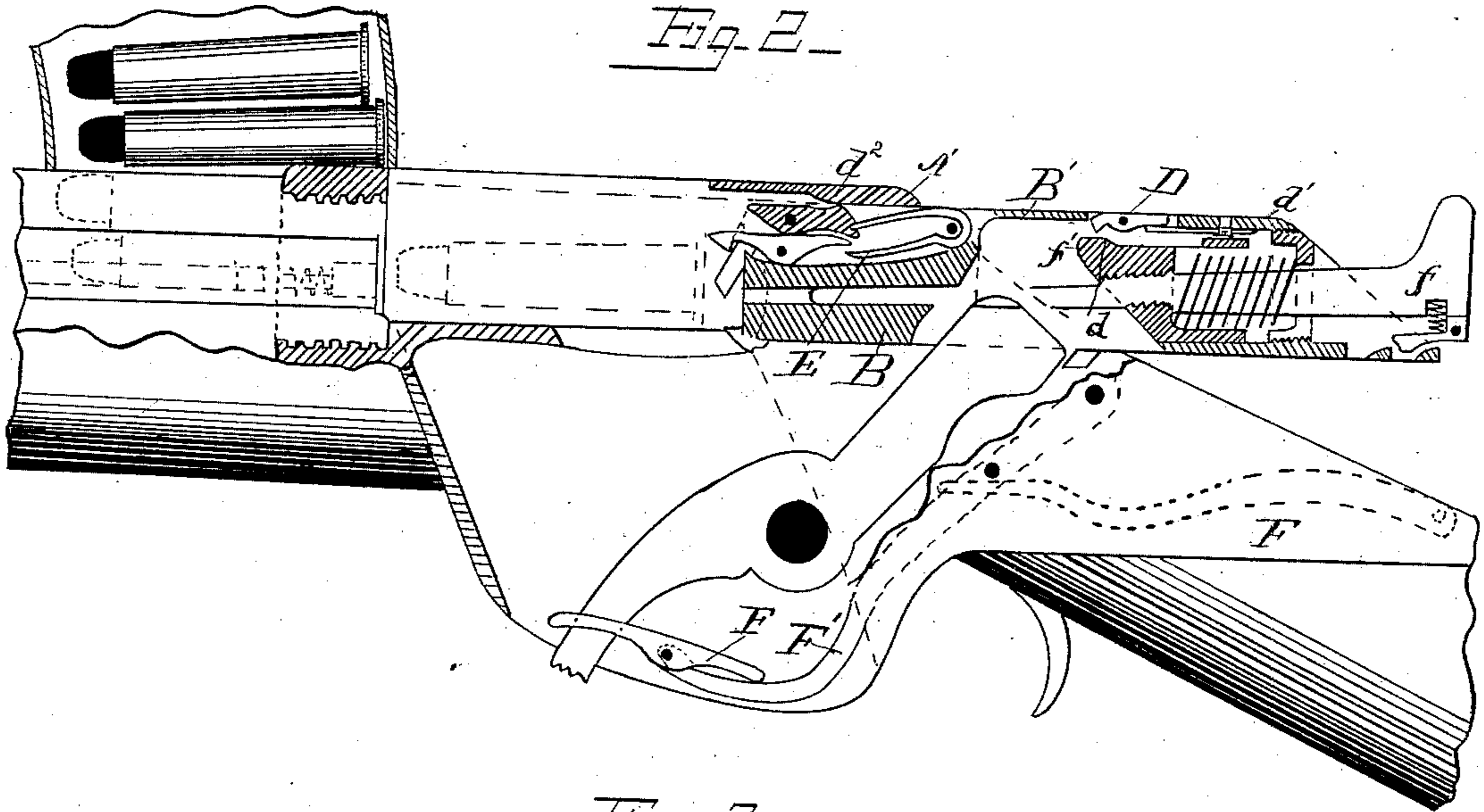

Witnesses

Philip Hawley,
G. W. Brown

Inventor

Andrew Burgess
per Wallace A. Bartlett
His atty.

UNITED STATES PATENT OFFICE.

ANDREW BURGESS, OF OWEGO, NEW YORK.

MAGAZINE FIRE-ARM.

SPECIFICATION forming part of Letters Patent No. 303,262, dated August 12, 1884.

Application filed January 8, 1884. (No model.)

To all whom it may concern:

Be it known that I, ANDREW BURGESS, a citizen of the United States, residing at Owego, in the county of Tioga and State of New York, have invented certain new and useful Improvements in Magazine Fire-Arms, of which the following is a specification, reference being had therein to the accompanying drawings.

The object of my invention is to provide a magazine-gun of sure, simple, and rapid operation; and said invention consists in various improvements on those shown in my Patents Nos. 210,091 and 213,867 and the application of an additional magazine and changeable loading-case, together with other combinations and arrangements of parts, hereinafter more fully set forth.

Figure 1 is a longitudinal side elevation in section with breech closed and at half-cock, and showing the oblique magazine; Fig. 2, a similar view from the other side with breech open, and showing position of both magazines. Fig. 3 is a top view of bolt, showing the position and relations of magazines thereto. Fig. 4 is a cross-section of Fig. 1 on line $x x$, looking forward, and shows the raised parts of bolt and frame, the butts of the cartridges in rear magazine, and in dotted lines a cartridge as just drawn from the forward magazine and in the position it takes when ready to feed into the frame. Fig. 5 is a detached view of the ejector and extractor. Fig. 6 is a bottom view of the feeding and separating lever and cross-section of same on line $y y$, but right side up. Fig. 7 is the loading tube or case; Fig. 8, part of the loading-case, showing the beveled top springs, $S S'$, holding the cartridges in the magazine.

This gun, as shown in Figs. 1, 2, and 4, has a hollow frame, A , furnished with a reciprocating breech-bolt, B , which is moved and locked by the oblique lever L , as shown in my Patent No. 210,091. I add a projection, B' , to the bolt, which extends vertically upward so far as to allow a mortise closed at its top for the top end of the lever to rise and turn in without protruding through top of the bolt. The top of frame at A' , Figs. 1, 2, and 4, has a corresponding vertically-raised portion to receive and confine the raised top of the bolt, as particularly shown in cross-section,

Fig. 3, where A' is the raised top of the frame; B' , the raised top of the bolt; f , the firing-pin, and L the locking-lever. By this construction I am enabled to use the locking brace or lever L of full length and a bolt having a solid closed top, so as to dispense with the top cover generally used. The upper end of the lever thus comes between the usual locking-shoulder and the extended bearing on the firing-pin in the first movement of opening the breech, and thus crowds back said pin. I arrange the lock in the bolt and use a spiral spring to propel forward the firing-pin f . In the head of the firing-pin is a raised part, f' , which projects forward over the said pin and operating-brace, so that the brace L , in oscillating upward to unlock and move back the bolt, engages said projection to move the firing-pin backward within the bolt to cock it by its sear h engaging the notch h' in the bottom of the bolt.

In the above operation of cocking the gun to prevent the bolt from starting back too soon, and thereby produce objectionable friction of the face of the brace on its locking-shoulder, I pivot the dog D in the bolt and furnish it with a spring, d' , to turn its rear end upward to engage the notch d'' in the inside of the frame. This locks the bolt, so it cannot start back until the abutment d (in the process of cocking the firing-pin by moving it back in the bolt) engages the forward and inner projecting arm of the dog D to force said arm outward and turn the dog out of its engagement with the frame, and thereby leave the bolt free to move backward, as shown in Fig. 2. The extractor is pivoted in the forward end of the bolt, and an ejector, E , split at its lower part to work in slots at the sides of and below the extractor, and its upper rear end projecting above the bolt in position to be engaged and depressed by the abutment d'' in the frame when the bolt is carrying it back to the position seen in Fig. 2, and thereby its lower part caused to turn out forward of the face of the bolt to trip up and expel the cartridges by the assistance of the spring E' , which acts as a spring for such effect, and also, by engaging the extractor, its other end acts as a spring for that. The extractor and ejector may be hung on different pins, as shown

in Figs. 1 and 2, or both on one pivot, and the spring placed between them, as shown in the modification, Fig. 5, to act in the same manner. I arrange magazines M M' on each side of this arm, the rear magazine, M, being at the side of and below the frame, and the forward magazine, M', is placed at the side of and above the barrel at the opposite side of the gun. Both magazines may hold about ten or twelve cartridges, or the forward magazine may be removed when a less number is required. The rear magazine, M, is placed at the side of the frame, as shown in Figs. 3 and 4, and feeds the cartridges upward to the opening O, which leads into the frame on a level with the bore of the barrel. The top of this magazine at each end is furnished with the spring-studs S S', which, springing in over the ends of the top cartridge, hold it down in the magazine, as shown in Figs. 3 and 8, the top of the springs S S' being beveled, so that a vertical downward pressure upon them by a cartridge or loading-tube will press them so far back as to admit the insertion of the cartridges or loading-box. I prefer to use a spring at each end, as here shown; but by forming an overhanging abutment at either end it will serve to hold that end of the cartridge, the other spring forcing the cartridge thereunder to hold it in the magazine in substantially the same manner as when both springs are used; or a flat spring with like beveled top fixed to the side of the magazine will spring in to grasp the side of the cartridge, substantially as above. The top of magazine m, Figs. 3 and 4, is also furnished with a lever, T, which is pivoted in the rear top of the magazine or frame. Said lever has a short arm, t, which projects into a longitudinal groove, t', in the bolt when the breech is closed. The groove t' terminates in the abutment t'', forward, so that when the bolt moves back to the open position of the breech the said abutment t'', reaching the short arm t of the lever, oscillates it on its pivot to turn its long forward arm, t'', inward to the position shown in dotted lines in Fig. 3, which has the effect to drive the top cartridge laterally through the opening O in the frame to a position in front of the bolt, by which it will be forced forward into the barrel by the closing of the breech. An additional lever, as t^t, may be pivoted in the forward part of the magazine, and its rear end interlocked with the rear lever, T, so as to be moved thereby to bear against the cartridge to the rear of its center; or the lever T may have pivoted to it an oscillating follower like that shown at bottom of magazine in Figs. 1 and 2. The magazine-follower F, Figs. 1 and 2, is pivoted to a long arm or lever, F', which is hung to the frame to the rearward of the magazine, and is provided with a spring, F'', to swing the forward end of said arm and its follower F upward to raise the cartridges in the magazine. The arm F' and its spring are covered by a plate or backward extension of the magazine. The arm F', with

its follower, may be turned back and out of the magazine, as shown in broken lines, Fig. 1, to remove the cartridges from or load them into the magazine. As will be seen in Figs. 1 and 2, I make the magazine incline forward, as its front wall, m''', rises to terminate obliquely to the axis of the barrel. By this construction I utilize the recoil of the arm in firing, said recoil causing the oblique wall m''' of the magazine to strike the heavy points of the cartridges, to glance and raise them upward in the magazine, and thereby assist the action of the spring-follower, or remove any obstruction that may occur.

The magazine M may be loaded from below; but I prefer to load it from the top, and for that purpose I use a flat tube or loading-box of thin material, which holds the cartridges, and is capable of being thrust into the magazine in a similar manner to that of using the loading-tube described in my Patent No. 210,182; but this box, Figs. 7 and 8, holds the cartridges sidewise; and I prefer to make a vertical slot in one or both ends, as Z Z', Fig. 7, to permit one or both of the top springs, S or S', to snap over the top of the cartridges after the insertion of the box, to hold them down, so they may not be pulled out with the box or forced up by the follower while the springs S S' are compressed. By using only the rearward slot, Z, in the loading-box M'', and making it of sufficient width to permit the free movement of the arm F therein, I am enabled to leave said loading-box in the magazine, (the outer top being cut away at Z'', to allow the feeding-lever T to operate,) where it forms a part of or lining to the magazine, which may be withdrawn as fast as emptied and loaded ones inserted. I make the inner top of loading-box extend at the top far enough upward, Fig. 7, to be easily grasped, to withdraw it from the magazine. As an equivalent of the spring-studs of Fig. 3, I show like beveled top springs, S S', in Fig. 8, which consist of bent sheet metal, which extend downward, to be fastened to the bottom of the magazine. The forward magazine, M', is arranged on a base of similar construction and position to that described in my Patent No. 213,867, and the cartridges feed into it by the means ordinarily used in machine-guns. The reciprocating carrier is arranged in detachable relation to the bolt similar to that in above patent, but is provided with a lever for separating the cartridges and throwing them into the frame. I show the lever T', pivoted in the forward part of the reciprocating carrier C. (It may be pivoted in the forward part by a rear beveled short arm, to act in the same manner.) The top part of its long arm t^s is widened to pass between the cartridge on the carrier and that above, to separate them when it is turned into the position shown in dotted lines in Fig. 3, so that the flange of the upper cartridge may not obstruct a backward movement of the lower one. This is effected, when the carrier starts slightly forward, by the short

arm l^b of the lever as it reaches the slightly-raised abutment a , and is turned back thereby. The spring-stud a'' is arranged in the fore part of the carrier, to bear against the point of the cartridge thereon as the carrier moves back, so as to permit sufficient movement rearward of the carrier to turn the lever in to release the cartridge (if obstructed) before the cartridge shall be engaged by the unyielding part of the carrier to force it back. As soon as the cartridge is released from the upper one, the spring a'' will pass it back to the rear of the carrier, and thereby save any lost motion that the working of the separator would otherwise produce, so that but little more than the length of the cartridge rearward will be traveled to bring it in position opposite the opening O in the frame, when the short arm of the lever, reaching the higher abutment a' on the frame, is stopped, thereby to turn its long arm inward and drive the cartridge through the opening and into the frame forward of the bolt, as shown in dotted lines, Fig. 2. The springs S S', retiring without depression, may spring in to hold the cartridge in the magazine as soon as the cartridge is pressed down to the point at which they are to hold it, and thus save the space that a downward-rotating catch depresses the cartridge.

I do not herein claim, broadly, the dog D, in combination with the bolt and frame, the same being shown and described in an application filed by me May 17, 1884.

Having thus described my invention, what I claim as new, and desire to secure by Letters Patent, is—

1. In a bolt-gun, a brace, L, hung at the bottom of the frame, the upper end of said brace being arranged to swing upward and backward to open the bolt, the reciprocating bolt having a mortise extending upward through its body portion, which mortise receives the end of lever L, and a raised rib above the body of the bolt, which serves as a cover to said mortise, in combination with a frame having a top housing to receive said rib on the bolt, all substantially as described.

2. In a bolt-gun, the reciprocating breech-bolt having a locking-shoulder, the firing-pin placed longitudinally in said bolt, and having upward extension f' , with inclined front face, and the locking-brace L, having upward extension, which comes between said incline and the locking-shoulder, and by its combined wedge and lever action serves to move back the firing-pin; all combined substantially as set forth.

3. In the frame of a gun, a reciprocating bolt provided with a firing-pin, which moves longitudinally therein, in combination with a dog, D, hung in the bolt, and arranged to spring upward to engage an abutment in the frame to lock the bolt, and an abutment, as d , in the firing-pin to turn the dog and release the bolt on the backward movement of the firing-pin, substantially as set forth.

4. In the frame of a gun, a reciprocating bolt

provided with pivoted extractor and ejector, substantially as described, in combination with an abutment in the frame to engage and start the ejector as the breech is opened, and the spring E', which acts on both the ejector and extractor, substantially as specified.

5. A magazine fixed to and extending below the frame of a gun, and provided with means for feeding the cartridges sidewise and upward, substantially to horizontal alignment with the barrel, a spring or spring-projections arranged to enter the top of the magazine and hold the cartridges, the portion of said projections above their point of engagement being so beveled downward that a vertical pressure upon their top retires them horizontally to admit a loading box or cartridges, and permits them to spring back to hold said cartridges at the lowest position to which they may need to be depressed in loading, all in combination, substantially as described.

6. In combination with the breech mechanism of a gun, substantially as described, a magazine provided with mechanism for feeding the cartridges upward, as described, and the spring projections S S', having the inclined tops for the purpose specified, said projections being arranged to engage the ends of a cartridge to hold it in the magazine, all relatively arranged, substantially as and for the purpose set forth.

7. In a gun, a magazine arranged vertically at the side of the frame, an opening from said magazine through the side of the frame to deliver the cartridges laterally, a vibrating lever arranged in the magazine, in combination with movable breech mechanism to operate said lever, and thereby move the cartridge laterally toward the axis of the frame, substantially as described.

8. In a magazine-gun, a magazine arranged at the side of the frame, as described, and having an opening which extends through the side of the frame, and means to present the cartridges to a position opposite said opening, in combination with a vibrating lever, as T, and a reciprocating bolt arranged to operate said lever and move the cartridge sidewise into the frame, substantially as specified.

9. A magazine fixed to the frame and arranged to deliver the cartridges vertically upward to near the top of the frame, in combination with the spring-arm F' and a follower, as F, pivoted thereto to press the cartridges upward, substantially as described.

10. The frame A of the magazine-gun, the magazine M, fixed to the said frame, in combination with the pivoted spring-arm F' and its follower F, arranged to press the cartridges sidewise upward, substantially as set forth.

11. The frame of a magazine-gun, a magazine provided with cartridge-feeding mechanism, substantially as described, to force the cartridges upward therein, fixed vertically thereto, and having an opening at the top through which it delivers cartridges, in combination with a feeding-box which enters said

magazine from the top and remains in the magazine to serve as a lining thereto and deliver the cartridges upward, substantially as described.

5 12. In a magazine-gun, a reciprocating bolt, a magazine attached to the gun forward of said bolt, a reciprocating carrier, which is moved back by the bolt to deliver a cartridge to a position in the frame in front of the bolt when
10 the breech is open, and a vibrating lever, as T', hung in said carrier to strike the cartridge laterally in front of the bolt, all in combination, substantially as set forth.

15 13. A reciprocating carrier, a vibrating lever hung therein, which is provided with a long arm to move the cartridge laterally, and a short arm, as t⁶; to engage a fixed abutment,

as a', to turn the long arm against the cartridge when the carrier is moved back, substantially as specified. 20

14. In a magazine-gun, the reciprocating carrier C, a vibrating lever, as T', hung therein, a horizontal extension, t⁵, on the long arm of said lever, and a short arm, t⁶, in combination with a fixed abutment to turn the lever
25 and separate the cartridges, substantially as described.

In testimony whereof I affix my signature in presence of two witnesses.

ANDREW BURGESS.

Witnesses:

M. R. COOPER,
C. M. COOPER.