

(No Model.)

3 Sheets—Sheet 1.

T. A. EDISON.
ELECTRO MAGNETIC RAILWAY.

No. 263,132.

Patented Aug. 22, 1882.

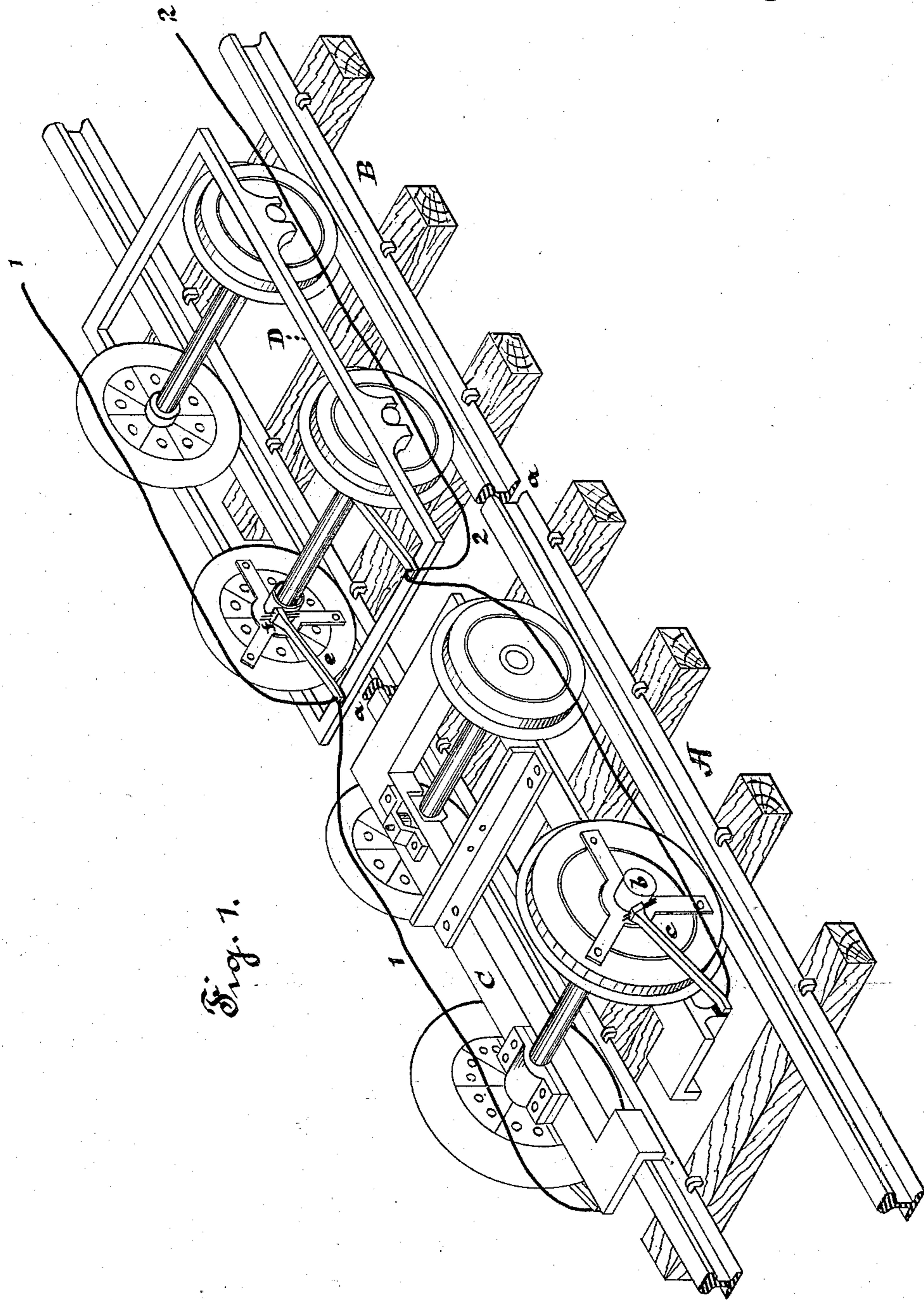

Fig. 1.

ATTEST =

D. W. Mott
J. A. Payne

INVENTOR =

Thos. A. Edison

ATTORNEYS.

(No Model.)

3 Sheets—Sheet 2.

T. A. EDISON.
ELECTRO MAGNETIC RAILWAY.

No. 263,132.

Patented Aug. 22, 1882.

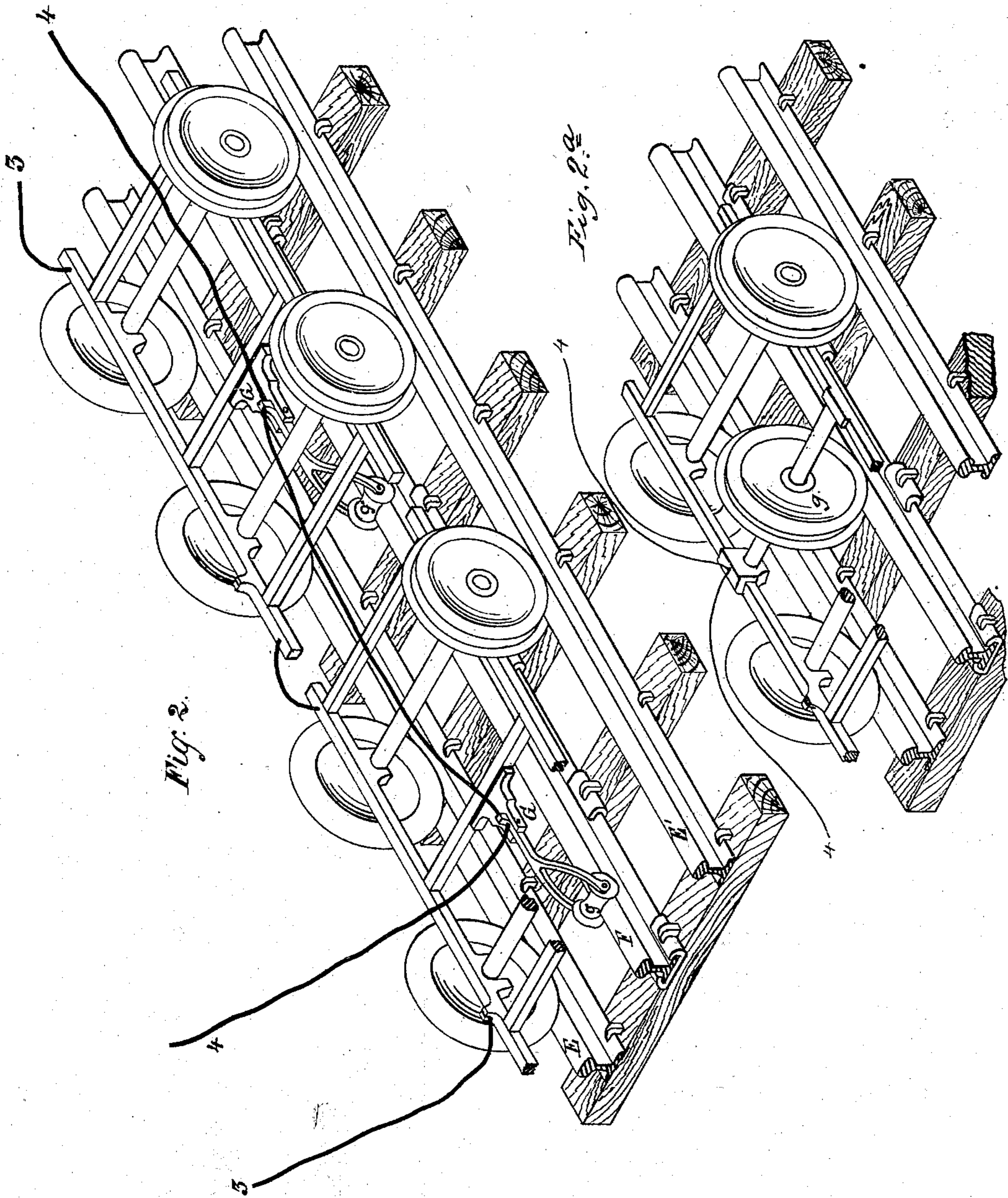

ATTEST:

D. D. Mott
J. A. Payne.

INVENTOR:

Thos. A. Edison

ATTORNEYS.

(No Model.)

3 Sheets—Sheet 3.

T. A. EDISON.
ELECTRO MAGNETIC RAILWAY.

No. 263,132.

Patented Aug. 22, 1882.

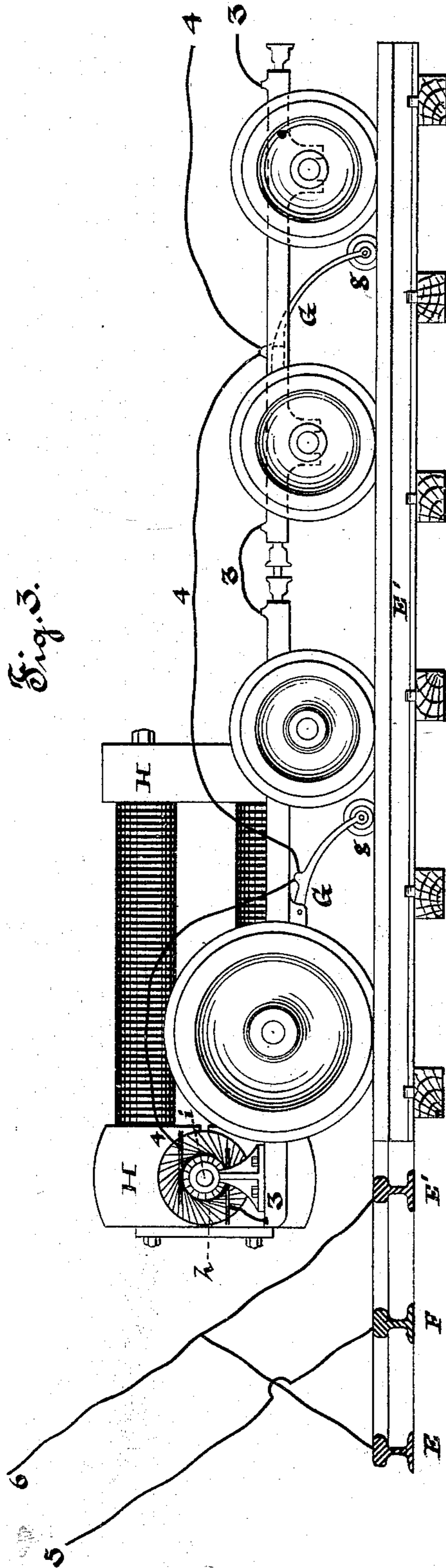

Fig. 3.

Attest
D. D. Mott
J. A. Payne.

Inventor
Thos. A. Edison

Attyo.

UNITED STATES PATENT OFFICE.

THOMAS A. EDISON, OF MENLO PARK, NEW JERSEY.

ELECTRO-MAGNETIC RAILWAY.

SPECIFICATION forming part of Letters Patent No. 263,132, dated August 22, 1882.

Application filed August 19, 1880. (No model.) Patented in England September 25, 1880, No. 3,894; in Canada March 31, 1881, No. 12,568; in India May 3, 1881, No. 341; in Victoria May 12, 1881, No. 3,012; in France May 27, 1881, No. 141,752; in New South Wales June 25, 1881; in Queensland June 30, 1881, and in New Zealand August 2, 1881, No. 542.

To all whom it may concern:

Be it known that I, THOMAS A. EDISON, of Menlo Park, in the county of Middlesex and State of New Jersey, have invented certain
5 new and useful Improvements in Electro-Magnetic Railways, (Case No. 329;) and I do hereby declare that the following is a full and exact description of the same, reference being had to the accompanying drawings, and to the
10 letters of reference marked thereon.

In my system of electro-magnetic railways, where the tracks themselves are used as the conductors, it is desirable to make some provision
15 guarding against cessation of effect of the current at crossings, switches, frogs, &c., or other places where it may be desirable to cut out a portion of the track from the circuit. In the
20 introduction of a system of electro-magnetic motive power upon roads already built and equipped for steam-transportation it may be desirable to make the change from one system to the other gradually, in order that the motive-power plant in use may be utilized to the
25 extent of its life. The accomplishment of these ends is the object of this invention.

Referring to the first object, it is to be noted that as a rule the greatest length of track necessary to be cut out of circuit will never exceed the average length of the trains, or even
30 the length of the shortest trains. Hence I prefer to make the electrical connections—bridging over the cut-out section—upon the train itself.

As explained in a prior application, I use in
35 my system the rails as the conductors, and upon the engine or motor car, or, so to speak, the locomotive, wheels having their flanges and hubs insulated from each other, and commutator-brushes arranged to form circuits by
40 means of suitable devices connected to the flanges through the motor from one rail to the other.

I now propose to use such commutator-brushes with the wheels of several of the cars
45 of a train, one of which cars should always be the last one in the train, all the commutator-brushes used on either side of the train being connected by a conductor to the appropriate commutator on the engine, the conductor be-

ing so arranged on the cars that they may be
50 readily connected. By this arrangement the cut-out section is electrically bridged over on the train itself, instead of by wires attached directly to the portions of the track in circuit.

In effecting the second object, so as to admit
55 of gradual change, arrangements must be made permitting of the use of both systems. To do this a third or central rail or conductor placed between the others is used, electrically connected in sections of suitable length, and thor-
60 oughly insulated from the bed. To the cars are attached arms carrying rollers or auxiliary wheels, taking upon the third rail, and conveying the current therefrom through the motor
65 upon the train, the ordinary rails being used as the return-circuit. These arrangements are shown in the drawings, in which—

Figure 1 is a perspective of the running-gear
70 of two cars, each provided with means for taking the current from the track, the cars being connected together; Fig. 2, a perspective showing the third or central rail and arrangements of circuits on the cars. Fig. 2^a is a perspective showing an extra wheel for use with the
75 third or extra rail; Fig. 3, a side view of an engine and car properly arranged and a cross-section of the three rails with circuit-connections.

In Fig. 1, A and B are two rail-sections, B
80 being an electrically-connected section, while A is cut out from the circuit at *a*, the section A representing a frog, switch, or other place where it is necessary or desirable to cut out electrically a part of the track. C D are the
85 frames of two cars, C being the engine or motor car, the wheels of which are constructed as before described—that is, with the hub and flange insulated from each other—a frame and
90 hub, *b*, insulated from the hub of the wheel, being connected to the flange, a commutator-brush, *c*, taking upon *b* and completing circuit to the engine. Wheels of the same construction are used with the car D, which is the last
95 of the train, any number of cars, all or some of which are similarly constructed, being supposed to intervene between C and D. Preferably the frame and hub upon ordinary cars are upon the inside of the wheels, as shown at *e*

and *f*. Conductors 1 and 2 run the length of the train, connecting all the commutators—1 upon one side and 2 upon the other. It is apparent, then, that when the engine-car has passed upon the cut-out section there will be no cessation of action thereon, as the current will pass from the conducting-section B through the wheels and commutators of car D, by conductors 1 2, to the engine. In the ordinary electrically - connected sections this arrangement has the advantage of making contact with the rails in many places, insuring perfect continuity of circuit, and lessening the spark due to any imperfect contacts consequent upon oxidized spots on the rail.

In Fig. 2; E E' are the rails of an ordinary railroad, which it is desired to gradually change to an electro-magnetic system. F is a third rail, laid preferably between the ordinary rails, and laid in chairs which thoroughly insulate it from the ties. From the one pole of the generator at the station or source of electricity a conductor, 5, leads to the central rail, F, while a conductor, 6, from the other pole leads to both the rails E E', as shown in Fig. 3. To the frame of the car, but insulated therefrom, is attached an arm, G, carrying a roller or wheel, *g*, taking upon the extra rail, F. Connected to this arm and wheel is a conductor, 4, which leads to the motor, from which a conductor, 3, completing the circuit therefrom through the iron or metallic parts of the car to the rails E E', which form the return-circuit. In practice *g* will be an extra wheel, in order to have weight sufficient to always insure good contact even when the extra rail is oxidized, it, by its weight, however, serving to prevent any accumulation of rust, and to keep the surface of the rail bright. In Fig. 2, for convenience of illustration, it is shown as a roller, while in Fig. 2^a it is shown in the preferred

form, an extra wheel upon an axle mounted in bearings insulated from the other wheels by the wooden frame-work of the car.

It is preferable to use an ordinary or common rail for the extra conductor, inasmuch as they are easy to obtain, and as a large mass of conductor with little resistance is given thereby at less cost than to use a copper conductor or one especially prepared for the service.

By using ordinary rails, F, and ordinary wheels, *g*, no special appliances need to be prepared while the change is going on, the method shown demanding in its carrying out only the materials usually employed or easy of obtainment and capable of use for their ordinary functions when their use in this connection is no longer needed. This central or extra rail should be thoroughly insulated from the other rails.

What I claim is—

1. The combination of a series of insulated wheels and commutator-brushes upon different cars, and circuit-connections through all upon each side of the train respectively to the commutator or commutator-brushes of the engine or motor, substantially as set forth.

2. The combination of an extra common or ordinary rail insulated from the others, electrically connected in sections to form one terminal or pole of the source of electricity, and the ordinary or traffic rails, one or both connected in sections to form the other terminal or pole of the source of electricity, substantially as set forth.

This specification signed and witnessed this 14th day of August, 1880.

THOS. A. EDISON.

Witnesses:

WM. CARMAN,
OTTO A. MOSES.