

J. & W. M. BRINKERHOFF.  
Fence-Hook.

No. 216,778.

Patented June 24, 1879.

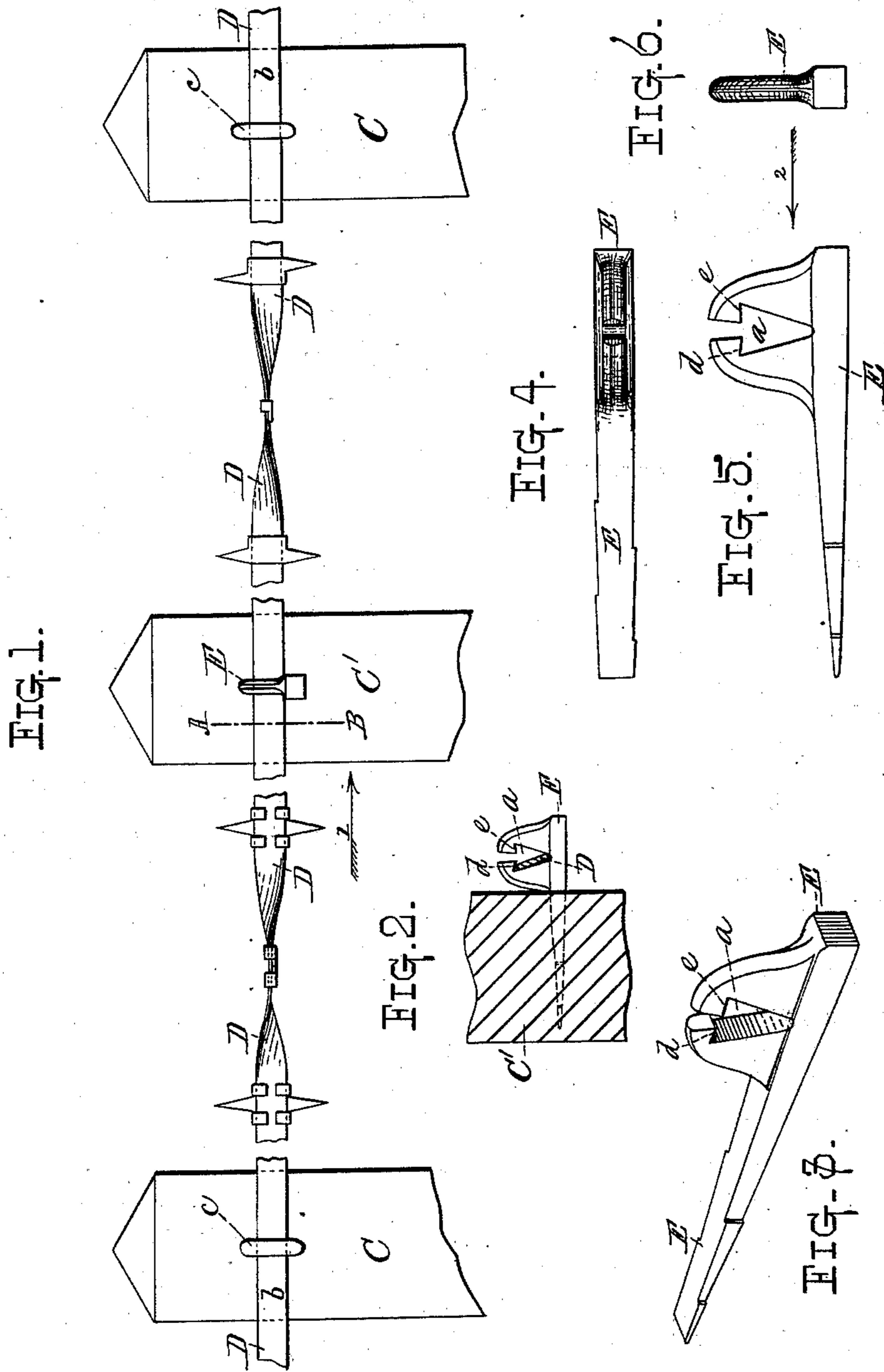

Witnesses =

*Thos. B. Dodge*  
*Edwin C. Moore*

Inventors =

*Jacob Brinkerhoff*  
*Wm. M. Brinkerhoff*

# UNITED STATES PATENT OFFICE.

JACOB BRINKERHOFF AND WARREN M. BRINKERHOFF, OF AUBURN, N. Y.,  
ASSIGNORS TO WASHBURN & MOEN MANUFACTURING COMPANY, OF  
WORCESTER, MASSACHUSETTS.

## IMPROVEMENT IN FENCE-HOOKS.

Specification forming part of Letters Patent No. 216,778, dated June 24, 1879; application filed  
May 12, 1879.

*To all whom it may concern:*

Be it known that we, JACOB BRINKERHOFF and WARREN M. BRINKERHOFF, both of Auburn, in the county of Cayuga and State of New York, have invented certain new and useful Improvements in Fence-Hooks; and we do hereby declare that the following is a full, clear, and exact description of the same, reference being had to the accompanying drawings, forming a part of this specification, and in which—

Figure 1 represents a side view of several sections of twisted flat-metal strip barb-fencing, showing the manner of fastening the same upon their respective fence-posts by means of staples and our improved fence-hooks, as hereinafter more fully described. Fig. 2 represents a vertical section through a portion of one of the fence-posts, taken on line A B, Fig. 1, looking in the direction indicated by arrow 1, and showing a side view of one of our aforesaid fence-hooks. Fig. 3 represents a perspective view of one of said fence-hooks; and Figs. 4, 5, and 6 represent a top or plan, side, and front-end view of the same, the four last-named figures being shown upon an enlarged scale.

To enable those skilled in the art to which our invention belongs to make and use the same, we will proceed to describe it more in detail.

In the drawings, C C and C' represent the upper portions of ordinary fence-posts; D, a strip of twisted flat-metal barb-fencing, said strip, for convenience in illustrating the same, being shown in short sections.

The operation of fastening and twisting one of the strips of barb-fencing D upon three posts, as illustrated in the drawings, is performed in the following manner:

The fence-hook E, which is provided with an angular-shaped slot, *a*, opening upon its upper side, is first driven into post C', as represented in Figs. 1 and 2 of the drawings, after which the ends *b b* of strip D are then secured to their respective posts C C by means of staples *c c*. The strip is then twisted, as represented in Fig. 1 of the drawings, by means of a suitable twisting device applied to the strip about midway between the two ends *b b*, at one side or the other of post C', and, after having been twisted as much as necessary to make the strip perfectly taut, it is then dropped and inserted into slot *a* of hook F, where it is held secure from untwist-

ing by bearing against one side or the other of said slot, as the case may be, and from displacement by the top of the strip coming under and against one of the projecting shoulders, *d* or *e*.

In this instance the strip D is represented in the drawings as being twisted from the post out. The strip therefore bears upon the side of slot *a* nearest post C', as represented in Fig. 2 of the drawings; but, if preferred, it may be twisted in the opposite direction equally as well, the strip in the latter case bearing against the outer side of slot *a* instead of as aforesaid.

Barbed strips D may be put up in as short or long strips as desired. In practice long strips are used, being fastened intermediately to fence-posts, first by staples *c*, then by fence-hooks E throughout the length of the strip, being twisted and so fastened in the manner hereinbefore described.

The strips are drawn as taut as possible by hand, when they are secured in position by staples *c*, so that when they are properly twisted they are perfectly taut and stiff.

After the fence has been put up for a considerable length of time, so that the strips have become slack or loose, they may be easily tightened again, so as to be as taut as when originally put up, by simply further twisting the same, as before explained.

It will therefore be seen that a perfectly taut and stiff fence is obtainable at all times by the employment of our aforesaid improved fence-hooks, and the manner of twisting and then securing the fence-strips in the same.

It is but a trifling expense to the owner to keep the fence in perfect repair, said expense being only the time occupied in retwisting, which is necessary only at long intervals.

Having described our improvement in fence-hooks, what we claim therein as new and of our invention, and desire to secure by Letters Patent, is—

As an improved article of manufacture, a fence-hook, E, provided with an angular-shaped slot, *a*, and holding-shoulders *d e*, substantially as and for the purposes set forth.

JACOB BRINKERHOFF.

WARREN M. BRINKERHOFF.

Witnesses:

THOS. H. DODGE,  
EDWIN E. MOORE.