

A. BURGESS.  
Magazine Fire-Arm.

No. 210,091.

Patented Nov. 19, 1878.

Fig. 1.

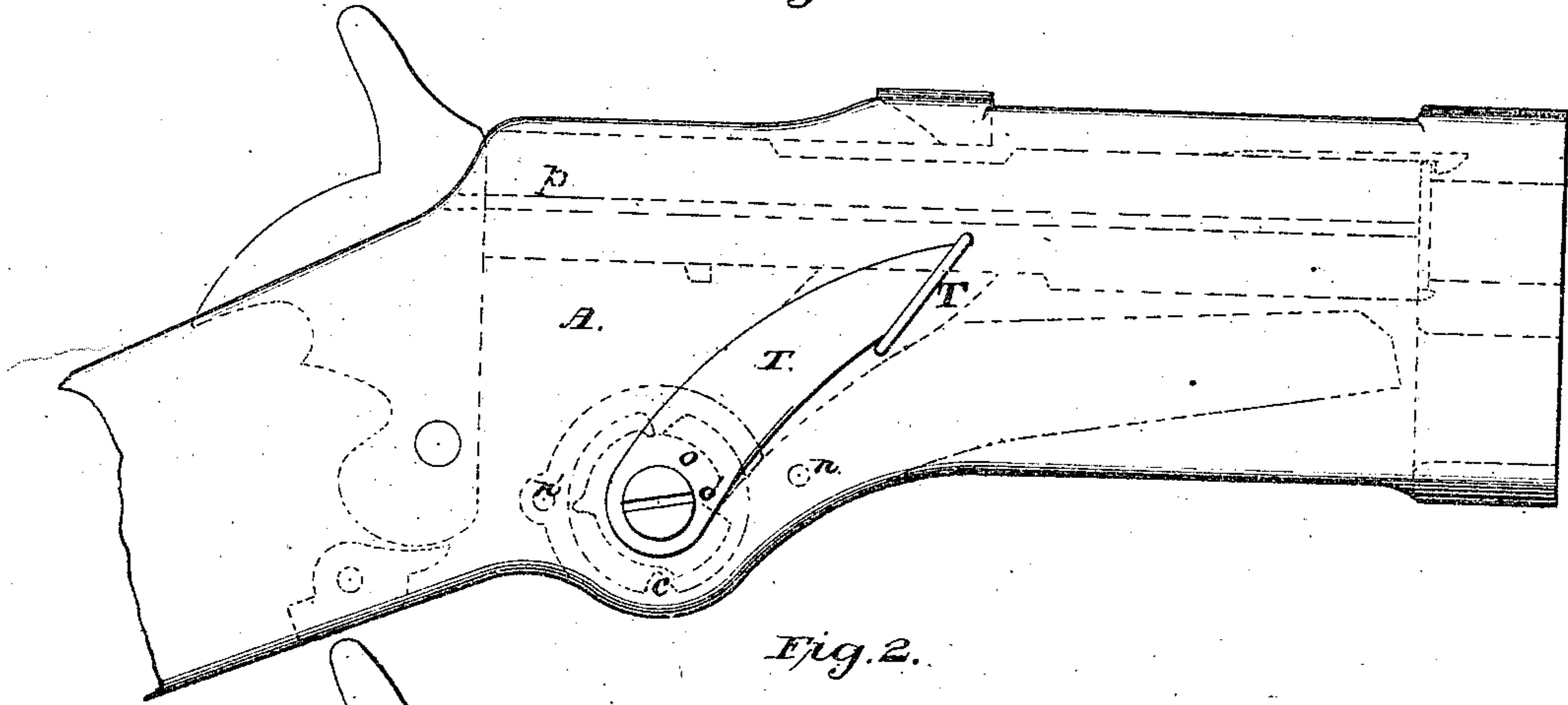

Fig. 2.

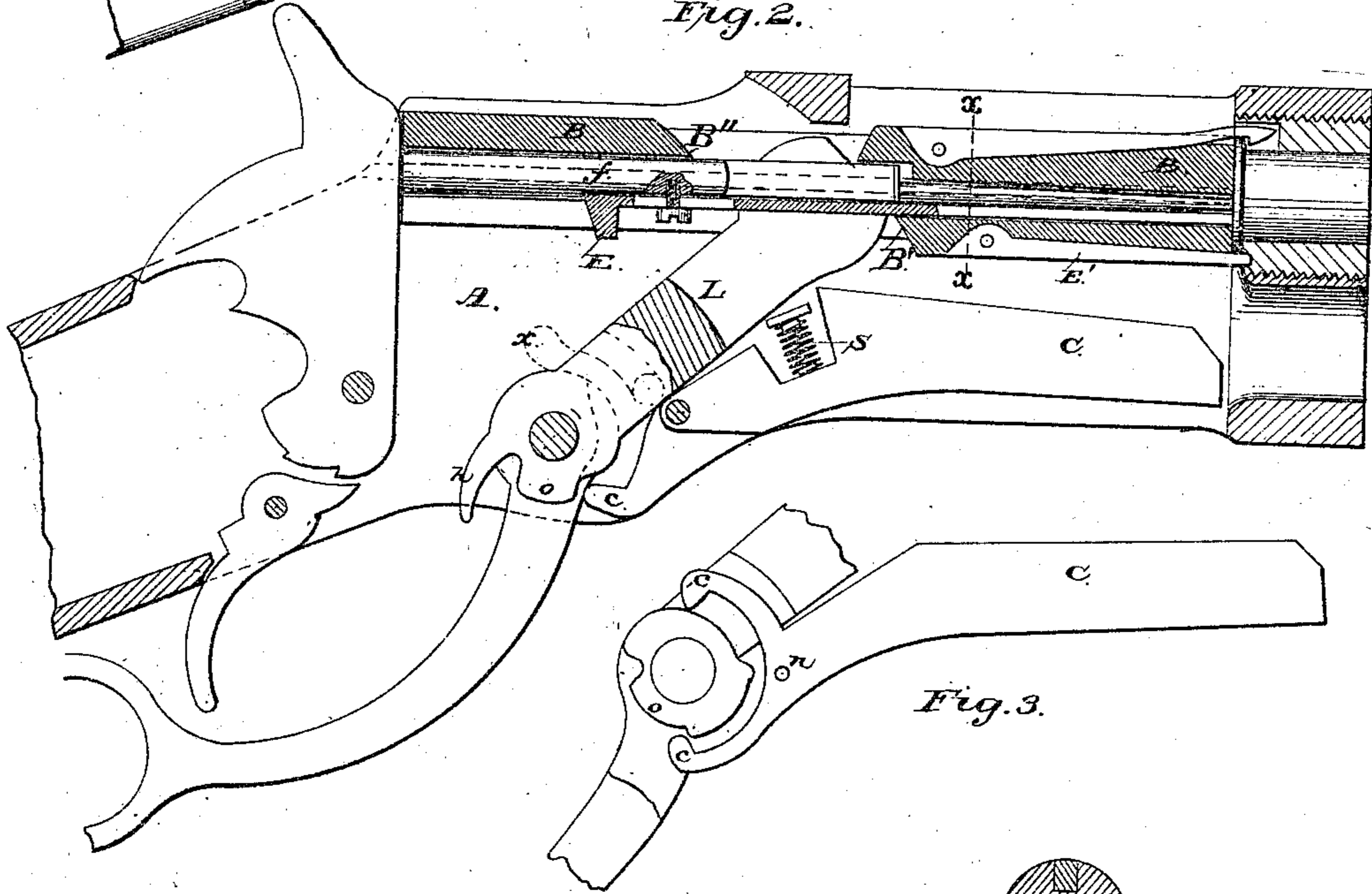

Fig. 3.

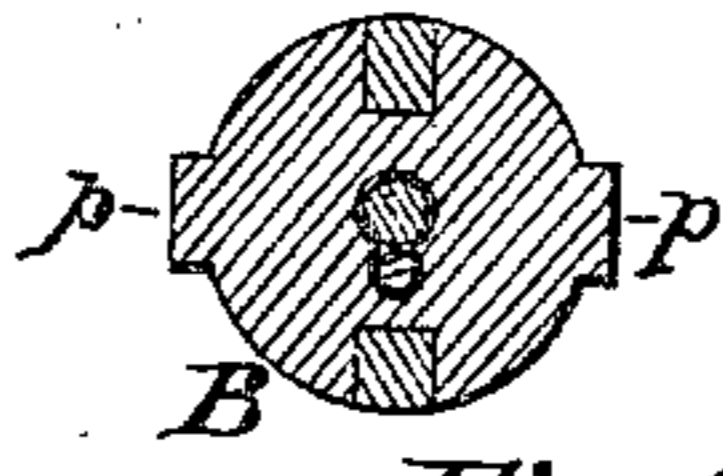

Fig. 4.

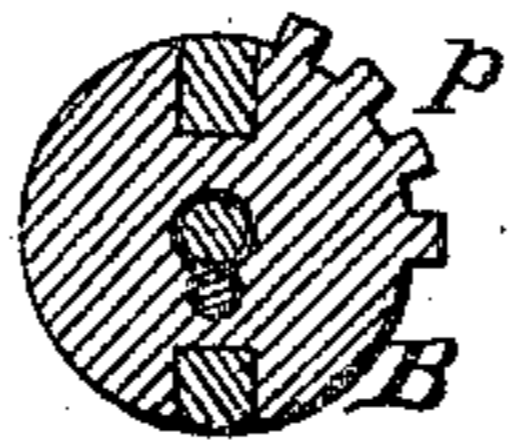

Fig. 5.

Attest:  
A. F. Tiffany  
C. A. Thompson

Inventor:  
A. Burgess

# UNITED STATES PATENT OFFICE.

ANDREW BURGESS, OF OWEGO, NEW YORK.

## IMPROVEMENT IN MAGAZINE FIRE-ARMS.

Specification forming part of Letters Patent No. 210,091, dated November 19, 1878; application filed August 31, 1877.

*To all whom it may concern:*

Be it known that I, ANDREW BURGESS, of Owego, in the county of Tioga and State of New York, have invented a new and useful Improvement in Magazine Fire-Arms, which improvement is fully set forth in the following specification, reference being had to the accompanying drawings.

The improvements in this arm consist, principally, in the method of operating and locking the breech-bolt, the construction of the carrier and feeding device, together with the general arrangement and combination of parts, hereinafter more fully explained and described.

In the accompanying drawings, Figure 1 is a side view of the arm, showing some of its works in dotted lines. Fig. 2 represents a sectional side elevation, and Fig. 3 a modification of the carrier and its operating device in section.

Similar letters of reference indicate corresponding parts.

The receiver A contains a breech-bolt, B, which is operated back and forth by the block L, provided with a thumb-piece, as in Fig. 1, or a guard-lever, as in Fig. 2. This block being pivoted in the frame below the breech-bolt, extends upward through a mortise in the breech-bolt, its upper end being split or slotted, to pass over the firing-pin and ejector. The mortise in the bolt B is extended in a segment down and forward, to allow the end of the block L to fall under at B', when in its most forward position to lock the bolt, the projections *p* of the breech-bolt, together with the top of frame, holding the bolt from rising.

It is obvious that the firing-pin and ejector can be split, that the block L shall pass between their two sides; or the bolt B can be cut away at its sides, and block L mortised or split to pass over it by mere change in construction.

The carrier C is pivoted forward of the axis of the breech-brace, (excepting in modification, Fig. 1, where a similar effect is produced by pivoting it in the rear,) and its forward end is caused to rise and fall by projections and depressions in circular part *o* of block L, outside of its pivot, operating against the point or points *c* of carrier, and to insure a

positive effect; or when spring S is omitted, the hook *h* is added, as in Fig. 2.

In Fig. 1 these variations in the segment *o* are reversed, to either reverse the movement of carrier, or allow the pivot *n* of carrier to be placed back of breech-brace or lever-pivot, as at *n'*, instead of *n*, Fig. 1.

In dotted lines, at *x*, Fig. 2, is a modification by which the operating point of carrier is concealed, and the carrier raised by the last part of the movement of opening the breech.

The ejector E, attached to the firing-pin in such manner as to allow it some free reciprocating movement, may be tubular, and inclose the firing-pin, or a rod alongside or below it, and has a part at E, projecting below the firing-pin. The firing-pin has two shoulders, the one in front to keep it from coming back too far, and the rear shoulder is struck by back of breech-brace, to force the pin back in the movement of unlocking the breech.

The breech-brace L is either continued in a guard-lever, by which it is operated, or is provided with a thumb-piece, T, as in Fig. 1. In Fig. 2 the carrier is pressed down by the spring S, which has the effect to press the point *c* into a depression in the breech-brace, to hold it in a locked or closed position.

To operate this arm, after the magazine has been charged the guard-lever is first turned forward or the thumb-piece T pulled back, as the case may be. The first part of this movement raises the end of breech-brace L from under the shoulder B', thereby unlocking the breech-bolt, and allowing it to take a backward movement. At the same time the rear of block withdraws the firing-pin by coming in contact with the shoulder *f*, and then, reaching the shoulder B'', it pushes the breech-bolt backward, which, pushing against the hammer, cocks and then rides over it, and the ejector E, striking the face of the hammer, is stopped to expel the cartridge-shell by the assistance of spring-stud E'. At the same time the point *c* of carrier, entering the recess *o'*, lowers the carrier to receive a cartridge from the magazine. Then the first part of the movement of closing the breech, raising the point *c* of the carrier onto the segment *o*, lifts the cartridge to a level with the barrel and in front

of the breech-bolt, which, by its continued forward movement, drives the cartridge into the barrel-chamber, and the end of breech-brace L, reaching the shoulder of segment at B', turns under it, which, by the assistance of the top of frame and ribs p, locks the breech securely while the arm is being fired in the ordinary manner.

Having thus described my invention, what I claim as new, and desire to secure by Letters Patent, is—

1. The combination of a mortised and shouldered breech-bolt with a pivoted lever working in the mortise or against the shoulders, to move and to lock the bolt, substantially as described.

2. The breech-bolt described, having a segmental surface, B', and shoulder B'', in combination with the pivoted brace, to move and lock said bolt, substantially as specified.

3. A swinging brace locking the breech-

bolt at an angle with the axis of the barrel, in combination with longitudinal ribs and grooves to resist the upward tendency of the breech-bolt, substantially as described.

4. The brace, the bolt, and the firing-pin, in combination, substantially as described, whereby the firing-pin is withdrawn by the unlocking of the brace.

5. The combination of the ejecting-pin and hammer, arranged and operating to expel the cartridge, substantially as specified.

6. A pivoted carrier provided with the point or points c, in combination with the segment or segments o of the pivoted lever, whereby the carrier is operated to rise and fall, substantially as described.

A. BURGESS.

Witnesses:

A. F. TIFFANY,  
C. A. THOMPSON.