

J. TIFFANY.
REFRIGERATOR-CAR.

No. 193,357.

Patented July 24, 1877.

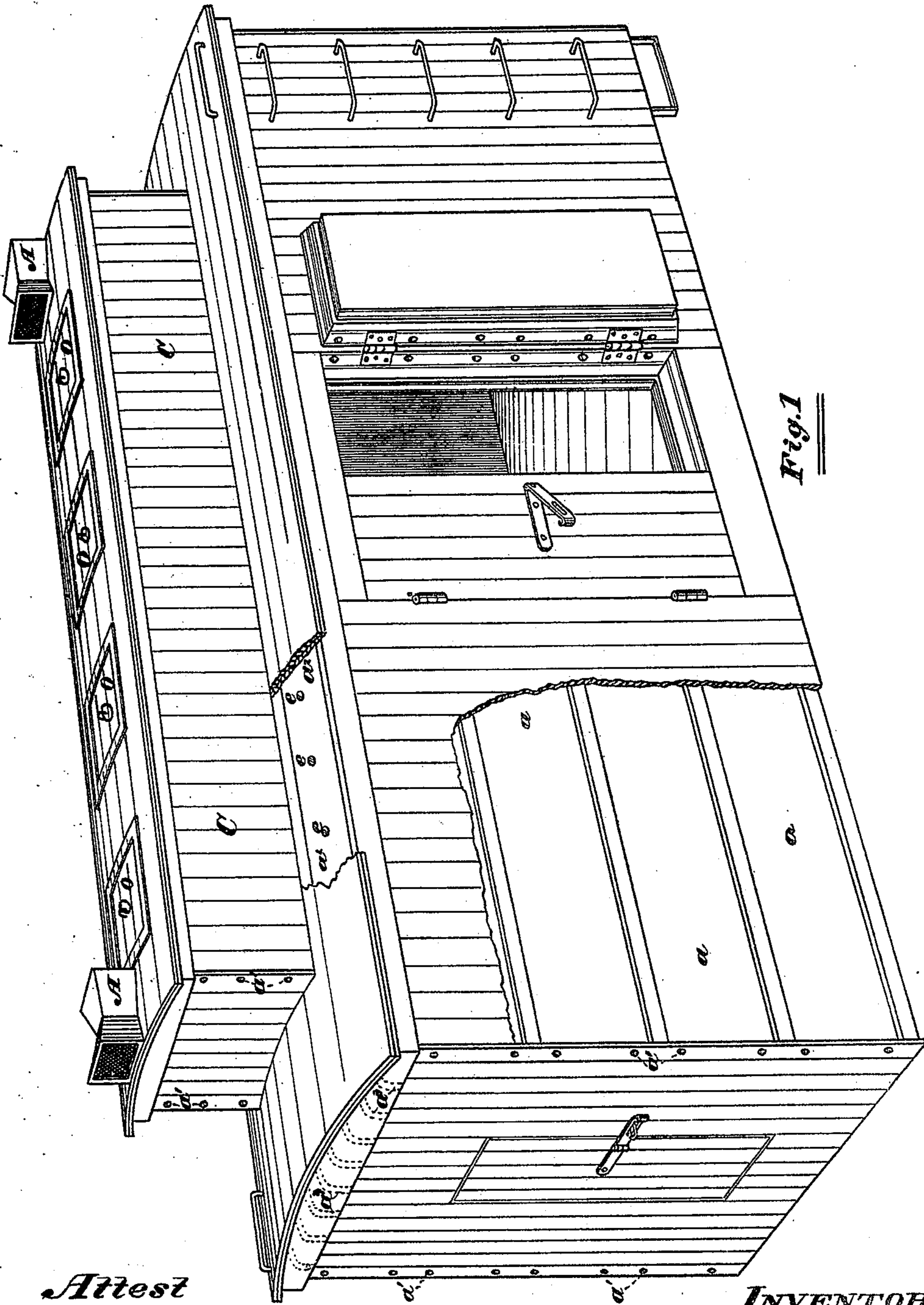

Fig. 1

Attest
W. L. Baker
A. J. Grover

INVENTOR:
Joel Tiffany

J. TIFFANY.
REFRIGERATOR-CAR.

No. 193,357.

Patented July 24, 1877.

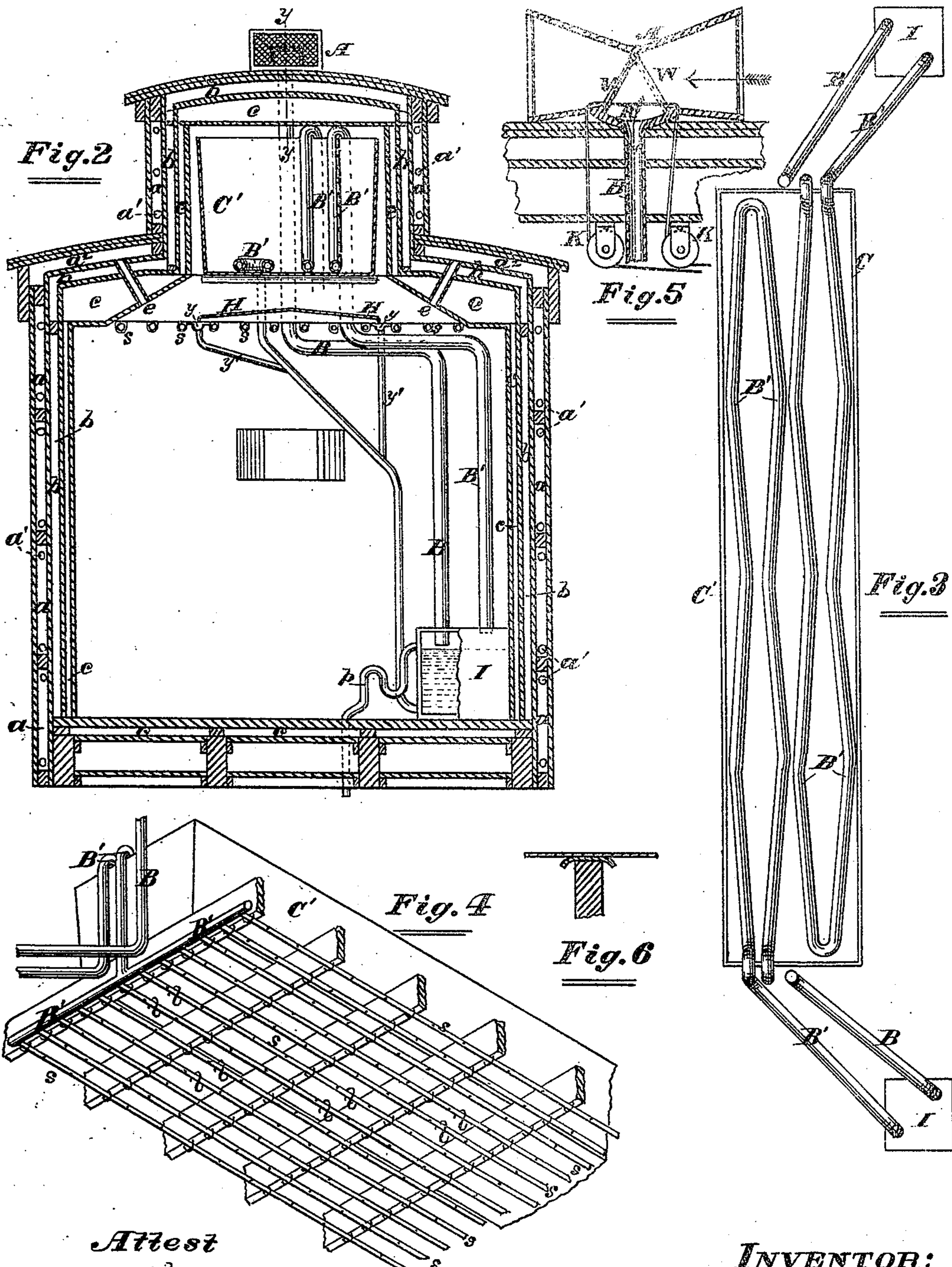

Attest
W. P. Baker
A. J. Grover

INVENTOR:
Joel Tiffany

J. TIFFANY.
REFRIGERATOR-CAR.

No. 193,357.

Patented July 24, 1877.

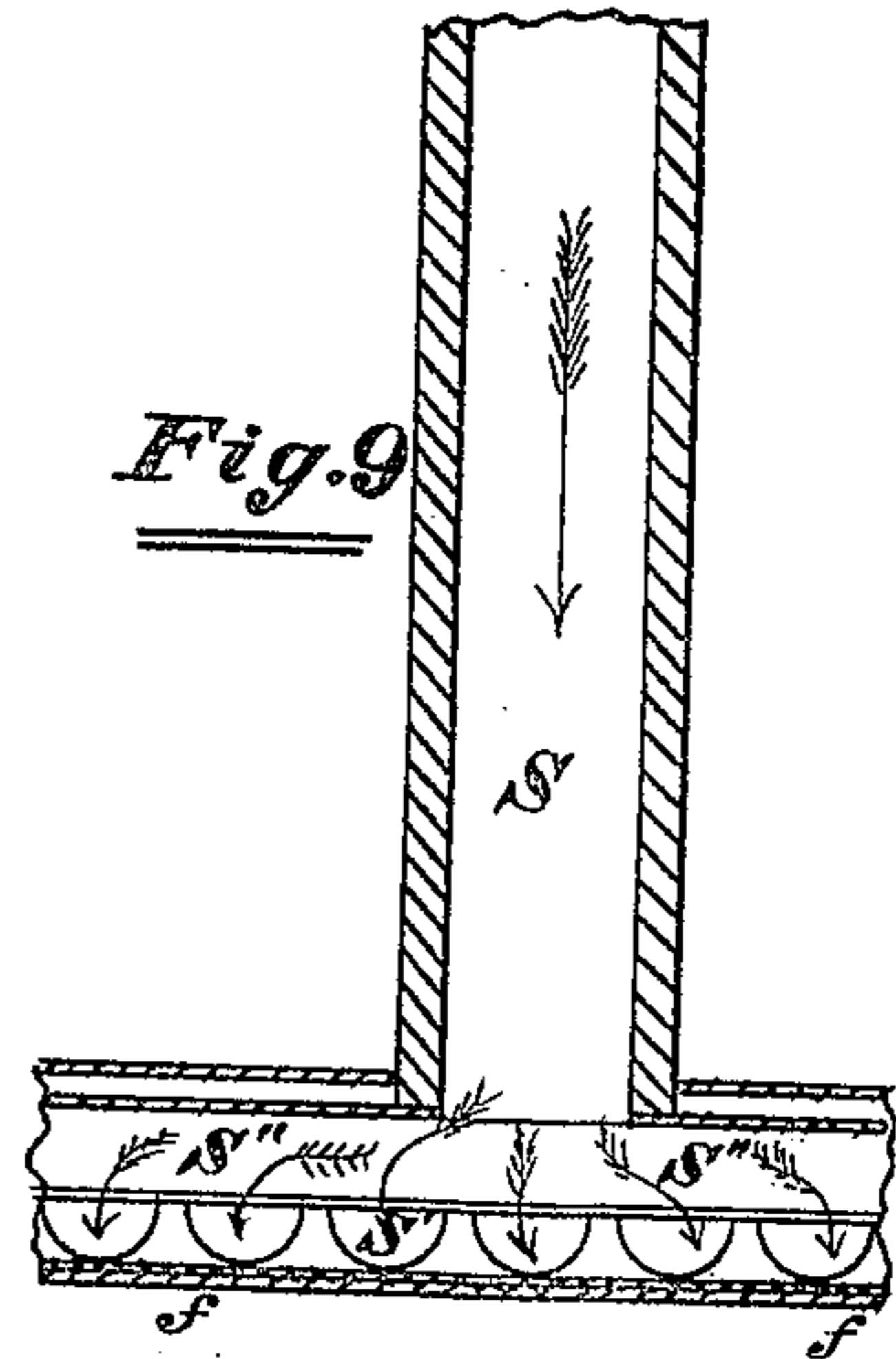
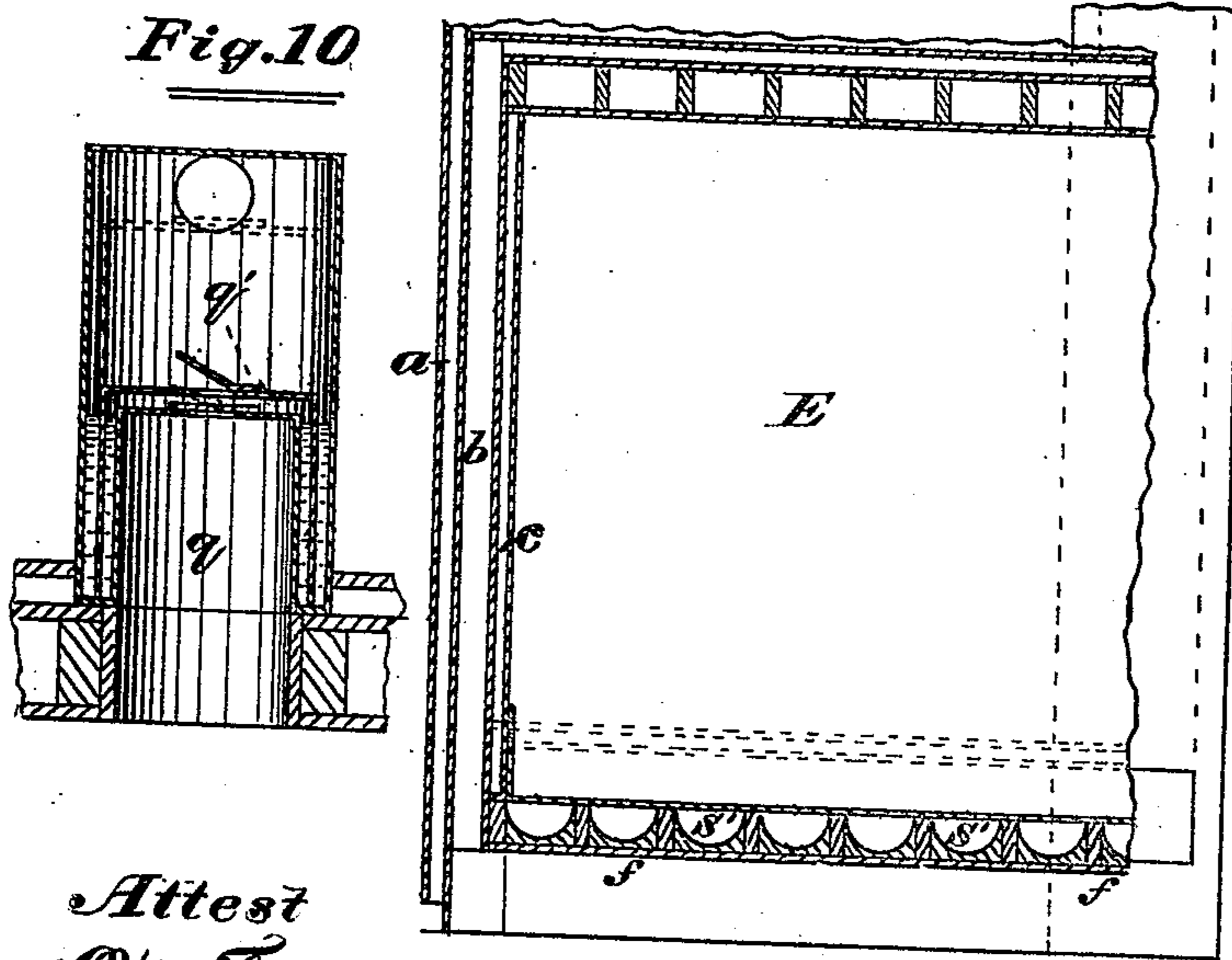
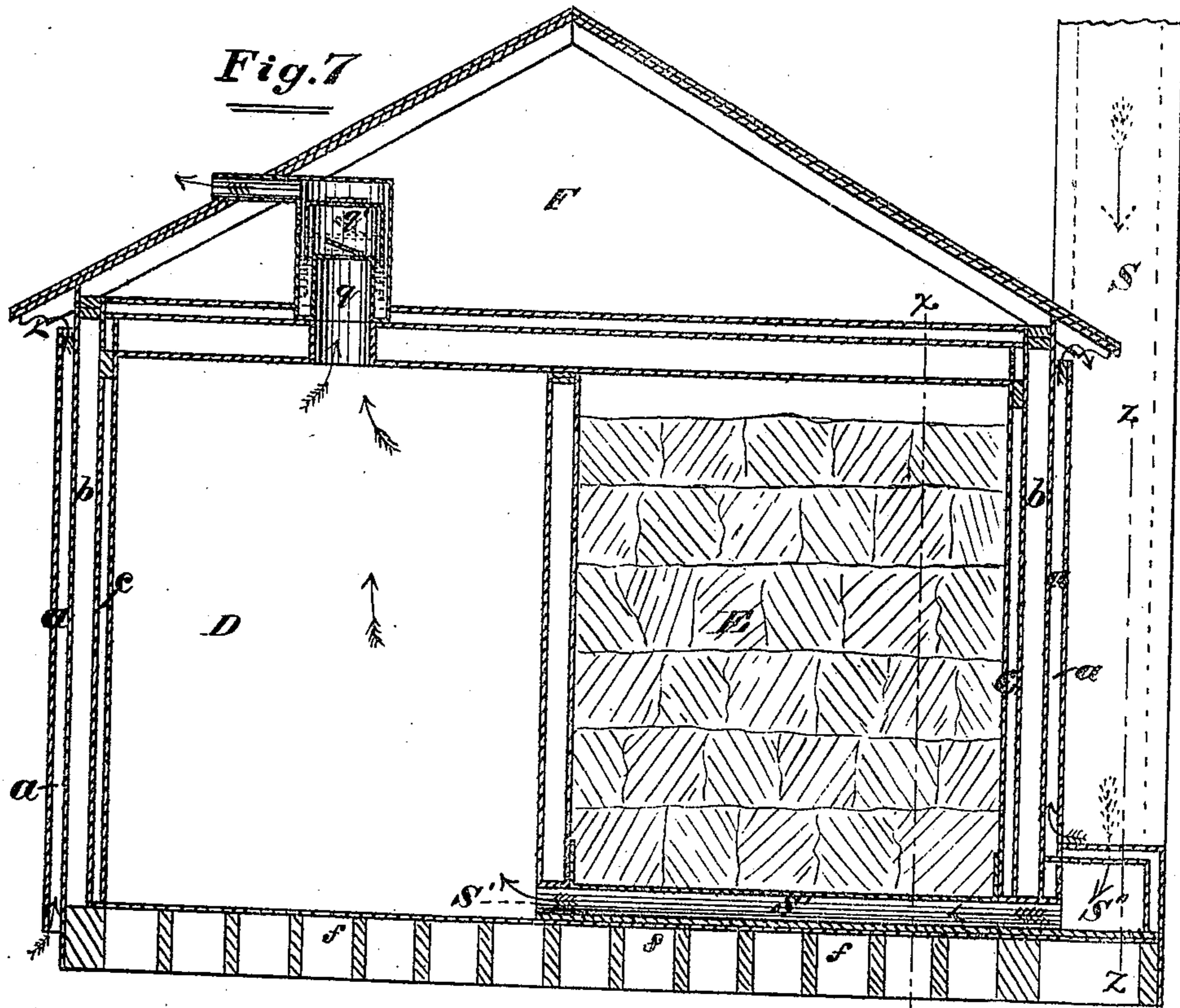

Attest
W. T. Baker
A. J. Hoover

Fig. 8

INVENTOR:
Joel Tiffany

UNITED STATES PATENT OFFICE.

JOEL TIFFANY, OF CHICAGO, ILLINOIS.

IMPROVEMENT IN REFRIGERATOR-CARS.

Specification forming part of Letters Patent No. 193,357, dated July 24, 1877; application filed January 22, 1877.

To all whom it may concern:

Be it known that I, JOEL TIFFANY, of the city of Chicago, county of Cook and State of Illinois, have invented a new and useful Improvement in the Construction of Refrigerating Cars, Rooms, Boxes, &c., for the transportation and preservation of perishable articles; and I hereby declare the following to be a full and accurate description of the same, reference being had to the accompanying drawings, and to the letters and figures marked thereon, and forming part of this description and specification.

My said improvement has reference to the manner of insulating, ventilating, and cooling rooms, spaces, cars, or buildings for the transportation, preservation, and storage of meats, fruits, butter, eggs, poultry, game, &c., and all perishable articles of a similar character.

My insulation consists in combining, with dead-air or packed spaces, spaces convertible from dead to live air spaces, and vice versa, at pleasure, without changing the structure of the inclosing-walls, substantially in the manner hereinafter described.

My ventilation consists in bringing into the refrigerator car, room, or box, or air-space, currents of dry, sweet, clean, cool air taken from without the same, and by it forcing out the warm foul air from the same through openings in the top or upper part of the same, without bringing the incoming air into contact with the ice in the room or ice-chamber, as shown in the accompanying drawings; and my method of cooling consists in the employment of an ice-tank, which may be placed above the space to be cooled, or on the side or bottom of the same, according to circumstances hereinafter described. When placed above the space to be cooled, the ice rests upon the bottom of the tank, which is made of galvanized iron, the under side of which is fully exposed to the air arising to the ceiling of the room to be cooled, when the warm foul air, coming in contact with the same, parts with its heat and moisture, and descends back to the lower part of the space to be cooled. In addition to this, I also pass dry clean air, taken from without the room, through pipes or flues under the ice in the tank or reservoir, into the space to be cooled, and there discharge

the same, substantially in the manner herein shown and described.

In the accompanying drawings, Figure 1 represents a perspective view of the application of my said improvements to a car, in which a part of said improvements are shown. Fig. 2 represents a vertical sectional view, taken at or near the end of the car, showing the manner of ventilating, insulating, and cooling the same according to my said invention. Fig. 3 shows the method of laying the air-pipes in the bottom of the ice-tank for cooling the air before discharging the same into the car. Fig. 4 represents the pipes or rods in the top of the car, from which meat or other similar freight is suspended, and also their relative position to the air-pipes, introducing dry cool air into the car. Fig. 5 represents the wind-sails in its structure and connection with the air-pipes, conducting the air to the water-tank in the body of the car. Fig. 6 represents the method of capping the car-lines upon which the ice-tank rests, to protect the carlines from the drip of condensation. Fig. 7 represents the same invention and improvements applied to a building or permanent structure for an ice-room and refrigerating-rooms, with the air-flue extending to the top of the building or above the same, and connecting with the pipes or flues running under the ice. Fig. 8 represents a sectional view of the ice-chamber, showing the ends of the horizontal flues passing under the ice. Fig. 9 represents the connection of the perpendicular air-flue with the horizontal air-flues running under the ice. Fig. 10 represents the structure and position of the exhaust, which is shown in the top of the chamber in Fig. No. 7, for the purpose of removing the warm foul air from the chamber, and bringing into its place cold, dry, and pure air through the perpendicular and horizontal flues therein represented.

My application of the aforesaid invention to a car is as follows: I take a car constructed like the freight-car in ordinary use. I construct air-flues running from end to end of the car horizontally on the outside of the same, substantially as follows: I attach to the sides of the car firmly strips of plank about two inches thick and three inches wide, and about

two feet apart, and running parallel to each other from end to end of the car. I then cover these strips with matched boards put on perpendicularly, thus forming horizontal air-flues running from end to end of the car two feet in width and two inches in depth, as shown in Fig. 1 of the accompanying drawing, *a a a*, the entrance to which flues is shown in said figure at *a'*. These form the changeable flues to be used as live or dead air spaces at pleasure—dead-air in cold or cool weather, and live-air in hot or very warm weather. This change is made by opening or closing, by means of corks or stoppers, the entrances to these flues at *a*, which are to be formed at both ends of the car. These spaces are likewise shown in Fig. 2 at *a a a a*, in combination with the packed and dead-air spaces, or packed spaces only, or dead-air spaces only. In Fig. 2 this combination is fully shown—to wit, the air-spaces *a a a a* already described with the packed or dead-air spaces *b* and *c*. This kind of insulation extends over the sides, ends, floor, and roof of the car, as shown in Fig. 2.

The ice-chamber *C* is in the top of the car, which is seen in Figs. 1, 2, and 4. The entrances to this ice-chamber are seen in Fig. 1, on the top of the same, at *O O O O*, through which the chamber is charged with ice. This chamber is likewise insulated in the same manner as the body of the car. Within this ice-chamber, and resting upon the carlines, is placed a large galvanized-iron tank for holding the ice for cooling the space in the body of the car or transportation chamber. In the bottom of this iron tank is placed the air-pipes *B' B'*, for conveying air under the ice from end to end and back, cooling the same, and discharging it into freight-chambers, in the manner hereinafter described. The manner of placing these air-pipes in the bottom of the ice-tank is shown in Fig. 3. The object of bending the pipes in the manner therein represented is to hold the ice from sliding about within the tank.

The manner of ventilating said car or room is shown in Fig. 2. The air-tubes *e e e* connect the chamber or body of the car with the ventilating-flues *a² a² a² a²* in the roof of the car, as seen in Fig. 1, which always discharge the air entering through the air-tubes *e e e* at the rear end and outside of the car, as shown in Fig. 1 at *a³ a³ a³*.

The method of conducting the dry cool air into the car is as follows: The air is taken in through the wind-sails *A A*, the air-pipes *B B*, the water-tank *I*, and the air-pipes *B' B' B' B'* under the ice, and is thence discharged into freight-chamber, either at the end of the ice-tank, or through the rods or pipes *s s s s*, as shown in Figs. 2 and 4. The air entering the wind-sails passes through the pipes *B B* to the water-tank *I*, thence up through the pipes *B' B'* under the ice into the body of the car, as shown in Figs. 2, 3, 4, and 5.

The air thus introduced into the car is freed

from dust, first, by means of a gauze screen fastened over the mouths of the wind-sails *A A*, as shown in Fig. 1. This wire-gauze is of a mesh of seventy to the inch. Second, the air is then conducted to the tank *I*, and thrown down upon the surface of water within the tank to free it from dust. It is thence conducted through pipes *B' B'*, &c., as above described. In this manner I fill the freight-chamber with sweet, dry, cold air, which forces the warm foul air out of the car through the air-tubes *e e e*, and air-flues in the roof *a a a*, in the manner already described.

The water of condensation from the bottom and sides of the tank of the ice-chamber is caught by the inclines *H H* extending under the entire bottom of the tank. This drip-water, with that from the melting ice, is conveyed through pipe *Z* to the water-tank, from which it is discharged through trap-pipe *p*, through the bottom of the car, as shown in Fig. 2.

The dry cold air introduced into the car, in manner before described, may be distributed through the pipes *s s s s*, as shown in Fig. 4, through openings on the under side of said pipes, as shown in said Fig. 4.

The structure of the wind-sails is shown in Fig. 5, which shows a section of the wind-sail *A*, with its swing-valve *V*, and stop *W*, or chamber through which the swing-valve moves over the opening *R* at the entrance of the pipe *B*. This valve may be operated by the force of the wind merely, or by a cord and pulley, *K*, as shown in said figure. By means of said cord and pulley the valve may be set at any desired position, so as to regulate the quantity of air to be admitted to the car. This cord may be conducted to any desirable part of the car for convenience of operating it.

The manner of capping the carline upon which the tank rests is shown at Fig. 6.

The manner of applying this invention to buildings and storage-rooms is as follows, reference being had to Figs. 7, 8, 9, and 10 of the accompanying drawings.

Fig. 7 represents a vertical section of a building containing a refrigerating-room, *D*, an ice-room, *E*, an exhaust-chamber, *F*, with their manner of insulation, and an exhaust-pump, *q* and *q'*, for removing the upper air of the refrigerating-room, as shown in Fig. 7, and illustrated in Fig. 10 of the accompanying drawings. When the air is taken from the upper part of room *D*, the air passes in from without through flues *S*, *S''*, and *S'*, under the ice, filling its place with pure, dry, cool air. The ends of the horizontal flues passing under the ice to be cooled are seen in Fig. 9, at *S'*, connected with the perpendicular flue *S* by *S''*, as represented in said figure. The foundations, with floor-joists and floor, as shown in Fig. 7, being properly laid in and upon the ground, the improvement is applied in this manner: three-by-three inch scantling are laid upon the floor, lengthwise of the flooring, and endwise toward the re-

frigerating-room, as represented in Fig. 8, about one foot apart. The spaces between the scantling being one foot wide, three inches deep, and in length extending from the refrigerating-chamber to the flue S'' in Fig. 9, are partially filled with a water-lime or other suitable cement, to the extent of covering the floor and the sides of the scantling, as shown in Fig. 7, at S' S'. On the top of this scantling is laid a tight galvanized-iron floor, converting the remaining spaces between the scantling into air-flues S' S', as shown in Figs. 7 and 8, connecting at one end with the perpendicular flue S through the horizontal flue S'', and at the other end with the refrigerating-room D, Fig. 7.

The ice in the ice-room is to be placed upon the iron floor, which constitutes the ice-floor.

The exhaust-pump q and q' may be constructed in any proper manner, and of any desirable number or size. The one represented in the drawings, Figs. 7 and 10, is constructed in the manner following: Insert through the ceiling of the refrigerating-room an inverted tank, of any desirable size, open at the bottom and closed at the top, with a valve in the top opening out, as shown in Fig. 7 at q' . Inclose the upper part of this inverted tank so as to make a circular cistern around the tank from one to two inches in width, extending from near the bottom of the tank to the top of the same, which, filled with water, will form a packing for a piston of the exhaust-pump. For a piston of this pump, a second tank is constructed like the one already described, only of a size sufficient to pass over the first tank q into the circular cistern. This tank q' is closed at the top, and has a valve opening outward, the same as in tank q , and is shown in Figs. 7 and 10. As the packing of this piston is a liquid—water, oil, or any suitable liquid—the friction in its operation is comparatively nothing, and, consequently, it can be operated with little power. In localities where wind can be relied upon the wind-sails A A, Fig. 1, can be employed. In other localities any mechanical means may be employed.

In the car as represented in Fig. 1 the operation is as follows: The car being freighted and closed against the access of external air, except as above described, the ice-chamber C' being charged with ice, the water-tank I being charged with water, as soon as the car is put in motion air enters the wind-sails A A, and passing down the pipes B B enters the tank I, and deposits any possible dust there-

in upon the surface of the water therein. It then returns through pipes B' B' under the ice in the ice-tank, is cooled, and emptied into the car in the manner already described. This forces the warm foul air in the car, if any, out through the air-tubes $e e e e$ into the ventilating-flues, $a^2 a^2 a^2 a^2$, and discharges the same at the rear end of the car.

When the external air is such that it is not desirable to admit the same into the car, the valves of the wind-sails may be closed; or, if it be desirable to change the air of the car very slowly, the valve may be set to admit only the desired quantity.

In cold or cool weather the flues on the outside of the car may be closed, and converted into dead-air spaces, as a protection against cold. In very warm weather the openings a' may be left open for the air to circulate through the flues $a a a$, as already described.

As applied to a building, as shown in Fig. 7, these outside ventilating-flues are shown in a perpendicular position. The course of the air-currents is indicated by the direction of the arrows. The internal arrangement is as follows: The exhaust-pump being separated by the application of any suitable mechanical device, the air in the top of room D is taken out of the top of the room, and its place is supplied by fresh, dry, clean, cool air, entering through the perpendicular flue S, the connecting-flue S'', and the horizontal flues running under the ice S' S', and, emptying itself into the lower part of the room D, is diffused through the room, imparting thereto a sweet, cool atmosphere.

Having thus fully described the nature, construction, and mode of operating my said invention and improvement, I will next set out what I claim as my invention and desire to secure by Letters Patent:

A refrigerator-car having its sides and top provided with an external jacket, forming horizontal air-passages extending the entire length of the car, said passages having openings at each end, provided with stoppers for converting the passages into dead-air chambers, in combination with dead-air or packed chambers constructed within and surrounding the body of the car, substantially as described.

In witness whereof I have hereunto set my hand this 8th day of November, A. D. 1876.

JOEL TIFFANY.

In presence of—

EDWARD McDONALD,
ALFRED BELLAMY.