

J. GRIDER.
Wagon-Brakes.

No. 157,324.

Patented Dec. 1, 1874.

Fig. 1.

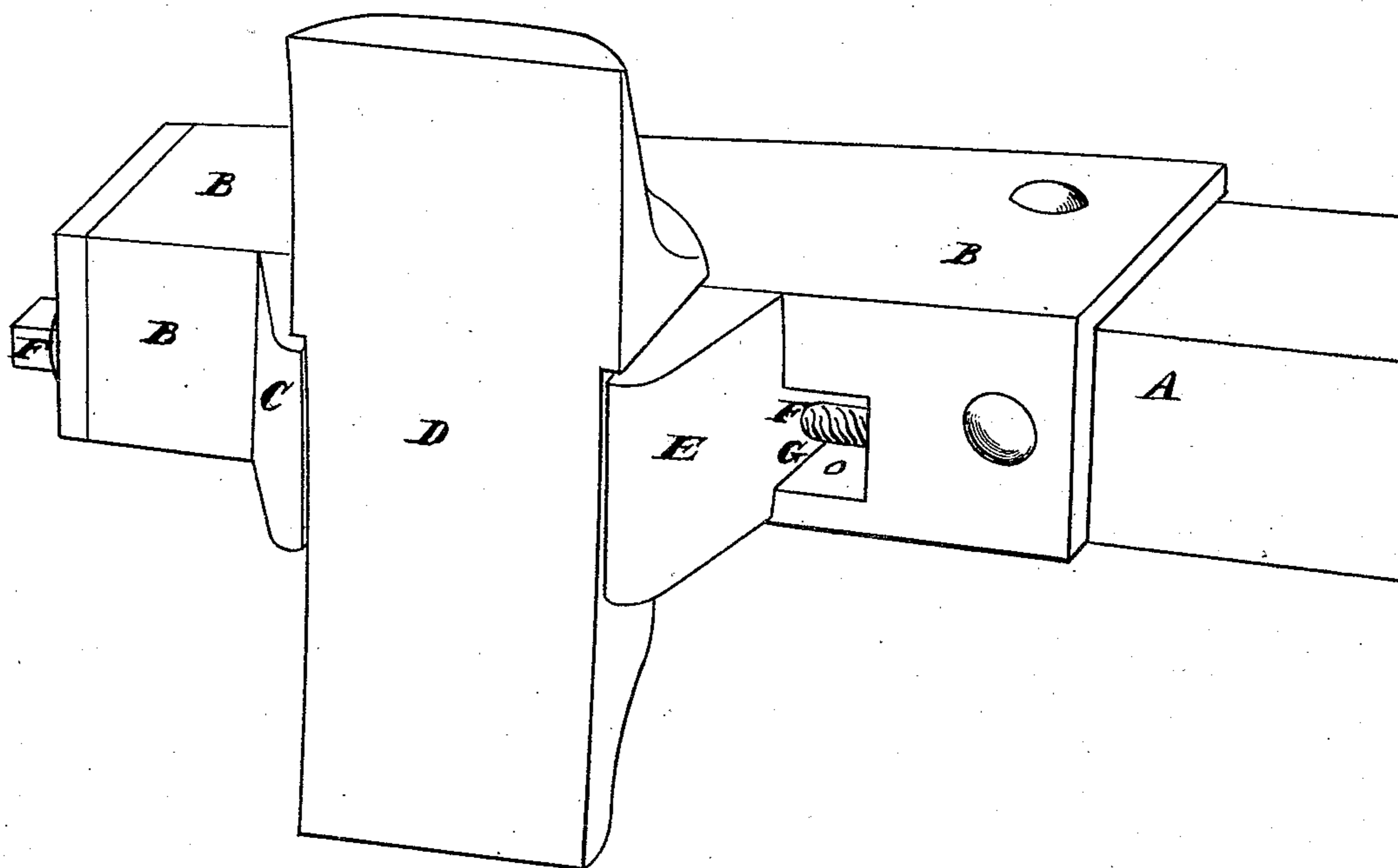
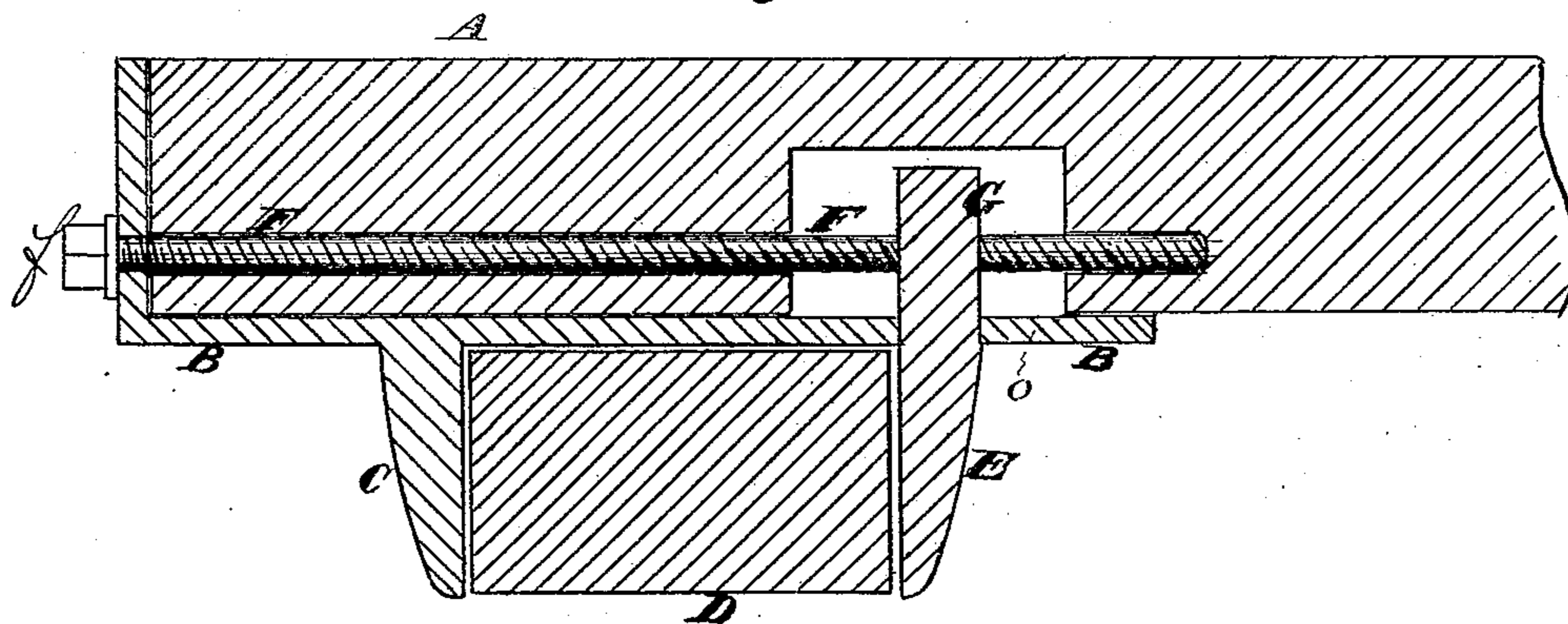

Fig. 2.



Witnesses
John L. Doone
C. M. Richardson

Inventor
John Grider
by Dewey & Co
Attys

UNITED STATES PATENT OFFICE.

JOHN GRIDER, OF MILTON, CALIFORNIA.

IMPROVEMENT IN WAGON-BRAKES.

Specification forming part of Letters Patent No. **157,324**, dated December 1, 1874; application filed October 15, 1874.

To all whom it may concern:

Be it known that I, JOHN GRIDER, of Milton, Calaveras county, State of California, have invented an Improved Wagon-Brake; and I do hereby declare the following description and accompanying drawings are sufficient to enable any person skilled in the art or science to which it most nearly appertains to make and use my said invention or improvement without further invention or experiment.

My invention relates to an improvement in wagon-brakes; and it consists in the use of a partial socket or cap of cast-iron, which is bolted to the end of the brake-bar, and has formed with it one jaw of a clamp, which holds the brake-shoe. A slot being made in the face of this cap, the movable jaw enters this slot, and a screw from the outer end of the brake-bar serves to operate this jaw and cause it to clamp the brake-block firmly.

Referring to the accompanying drawing for a more complete explanation of my invention, Figure 1 is a perspective view of my improved wagon-brake. Fig. 2 is a horizontal section.

A is one end of an ordinary brake-bar, which extends across in front of the wheels, and carries the shoe. My improvement consists in the use of a cap or partial socket, B, which

fits over the front, top, and the end of the brake-bar, as shown. This piece may be cast of iron, and has formed with it the stationary jaw C for holding the shoe or brake-block D. In order to make this shoe adjustable and removable when worn out, I employ a movable jaw, E, which has a lug, G, projecting through a slot, *o*, in the front of the plate B. A screw, F, passes through the end of the piece B, and a thread being cut in the lug G, through which it passes, it will be seen that, by turning the screw, the jaw E can be advanced or retreated. The shoe D is thus held by means of the jaws C and E, or released at pleasure, and the device is very durable.

Having thus described my invention, what I claim, and desire to secure by Letters Patent, is—

The angle-iron brace-piece B, provided on one side with the fixed jaw C and slot *o*, in combination with screw F, nut *f*, movable jaw E, and brake-beam A, all constructed as set forth.

In witness whereof I hereunto set my hand and seal.

JOHN GRIDER. [L. S.]

Witnesses:

JOHN HENRY OLLRICH,
J. G. POLLARD.