

Margaret E. Knight

PATENTED JUL 11 1871

116842

Bag Machine

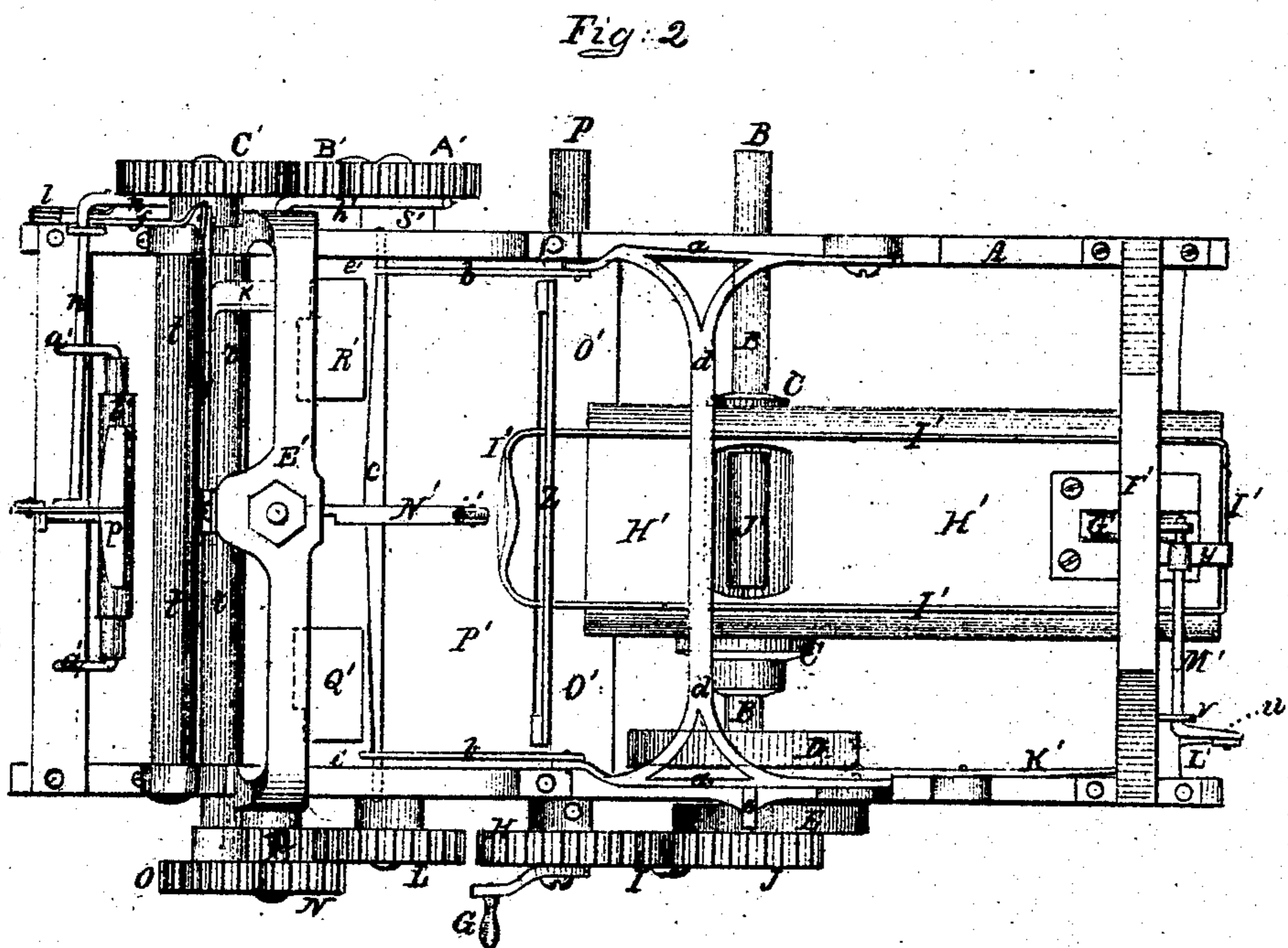
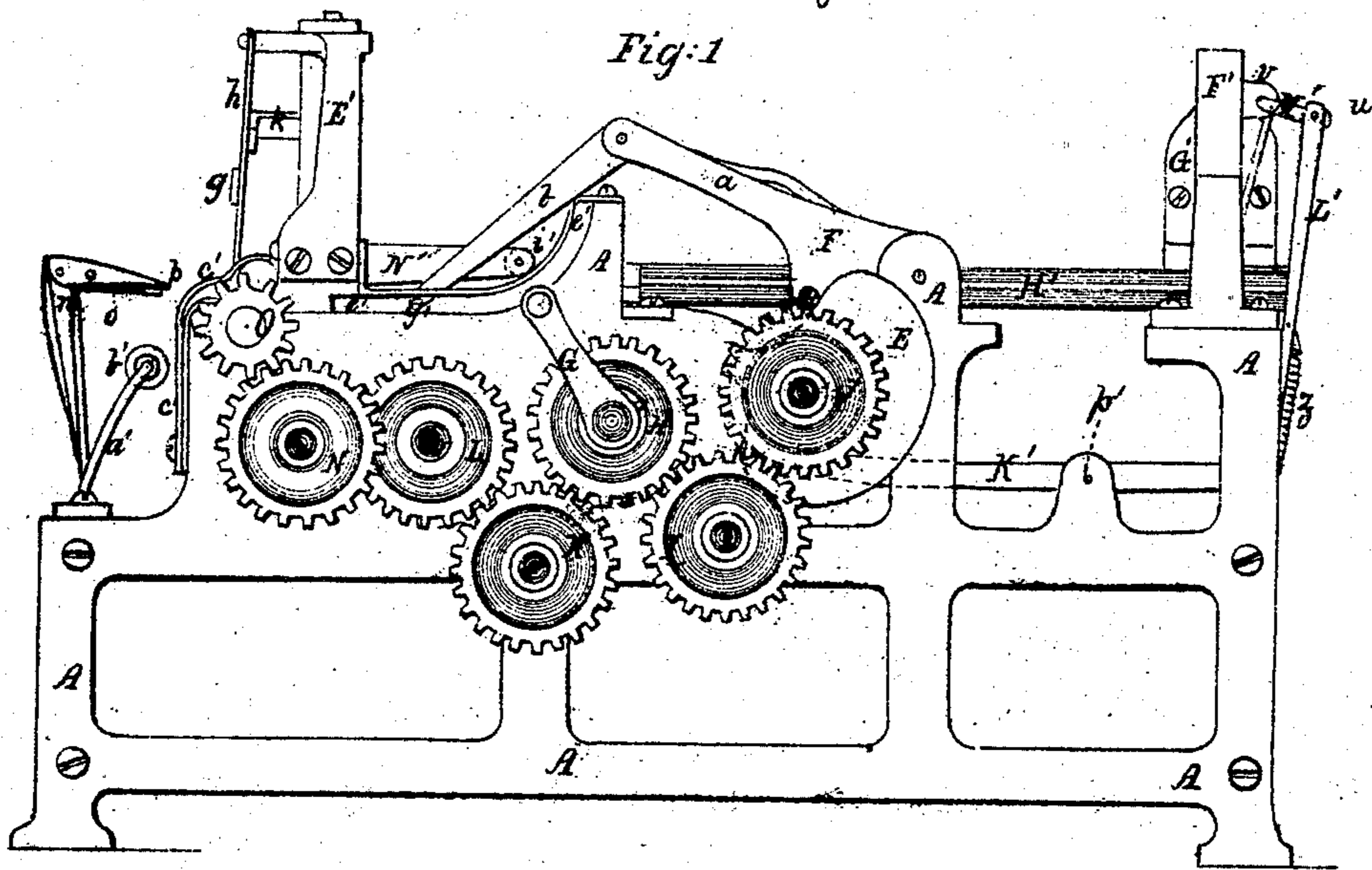

Witnesses
 A. C. Bradley
 Geo. C. Lambright

Inventor
 Margaret E. Knight
 By her Attorney
 Chas. F. Mansbourn

Margaret E. Knight

Bag Machine

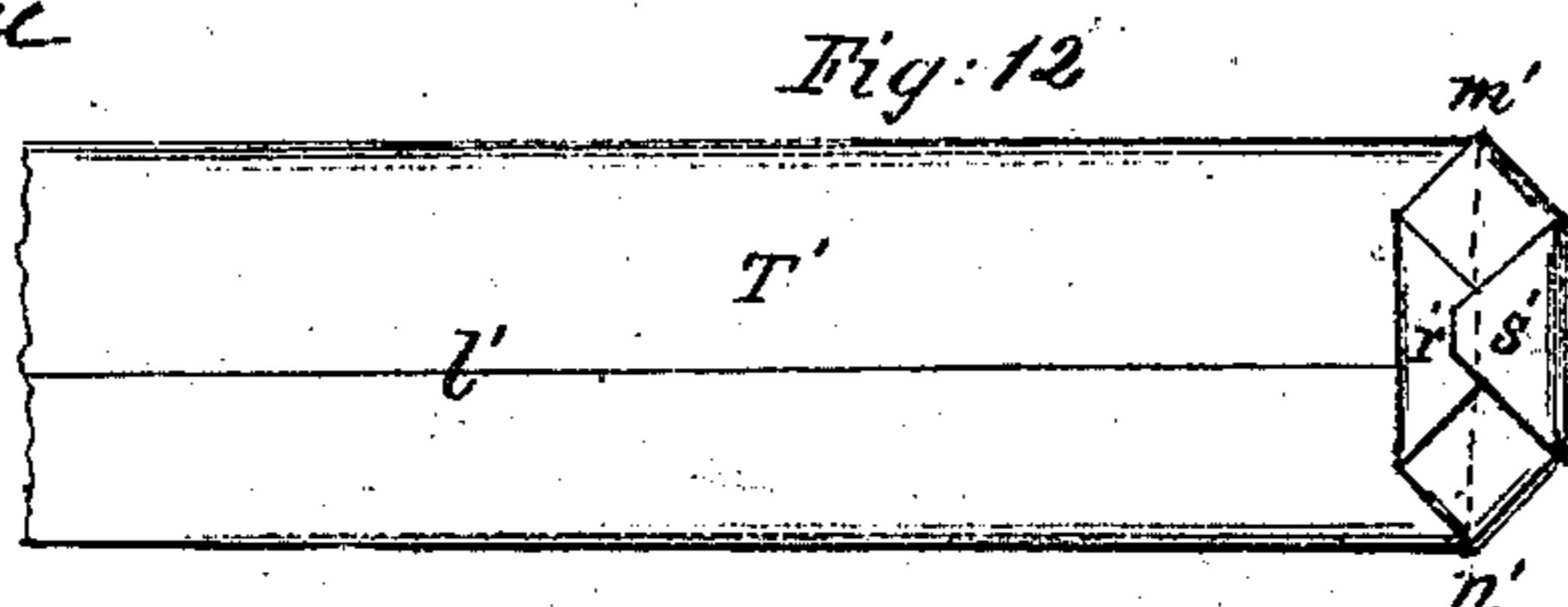
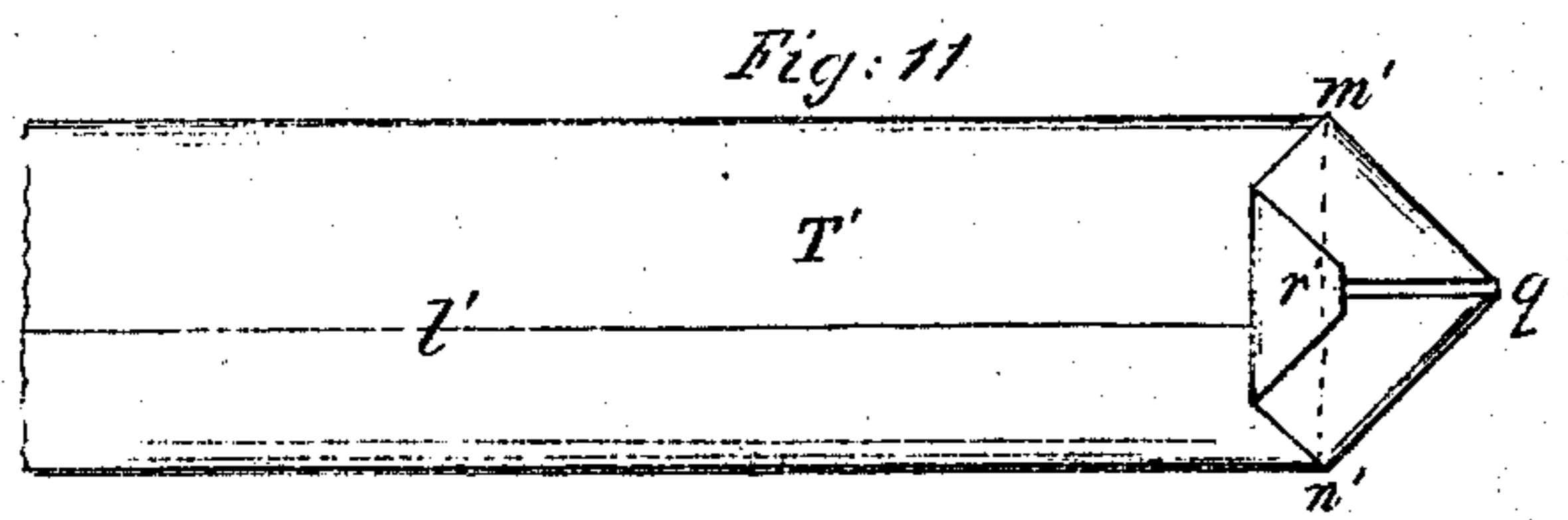
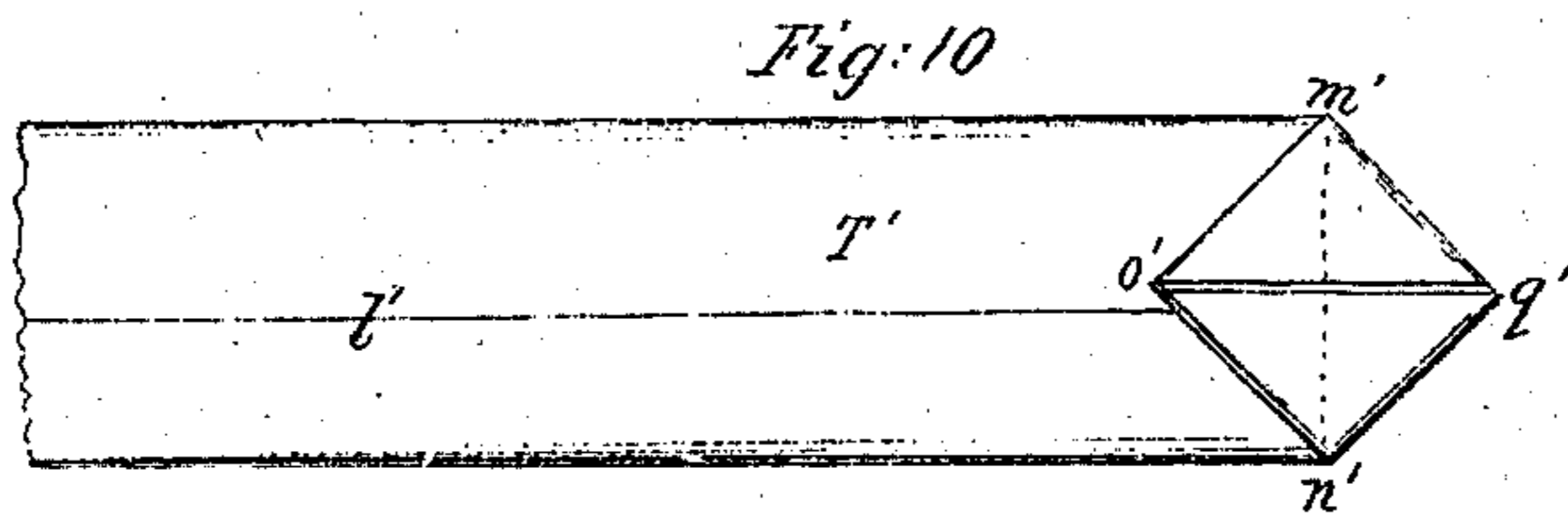
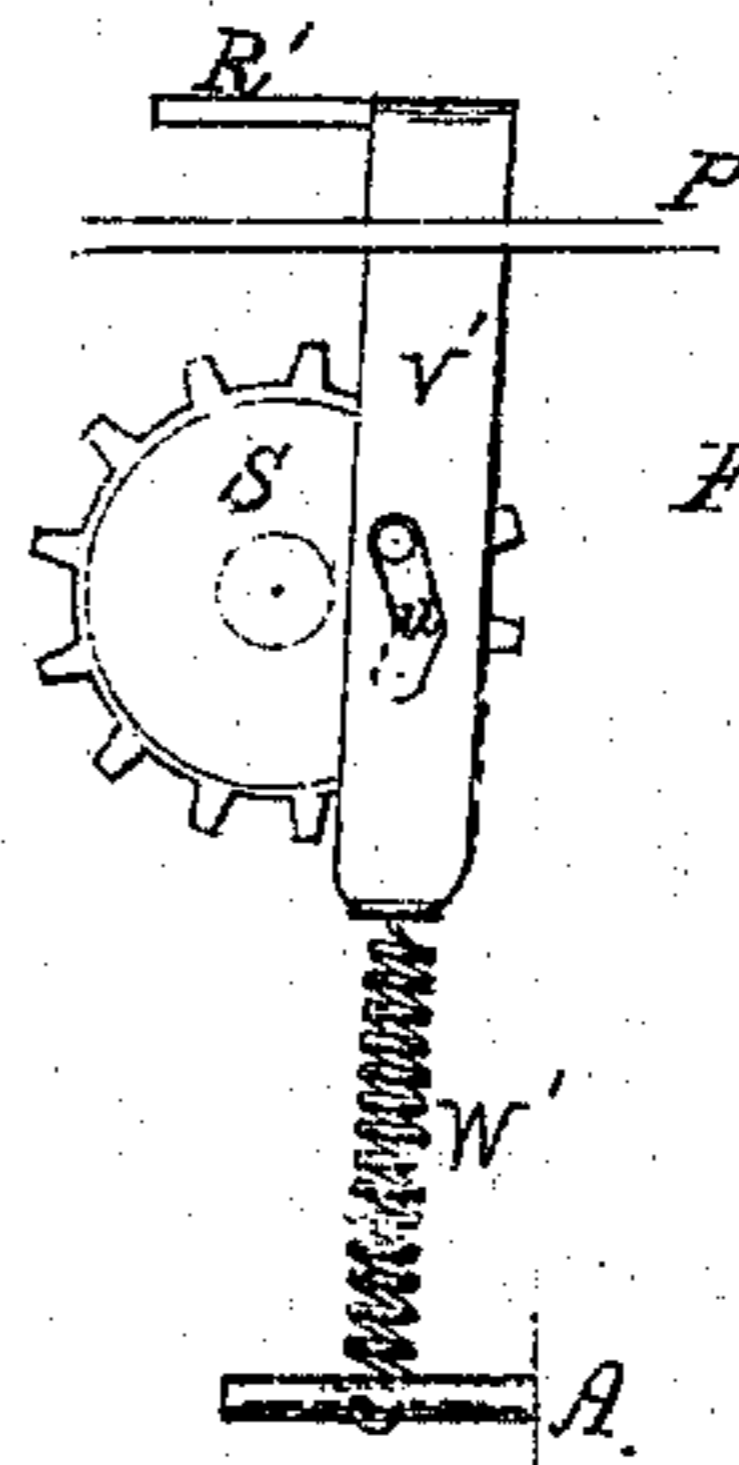
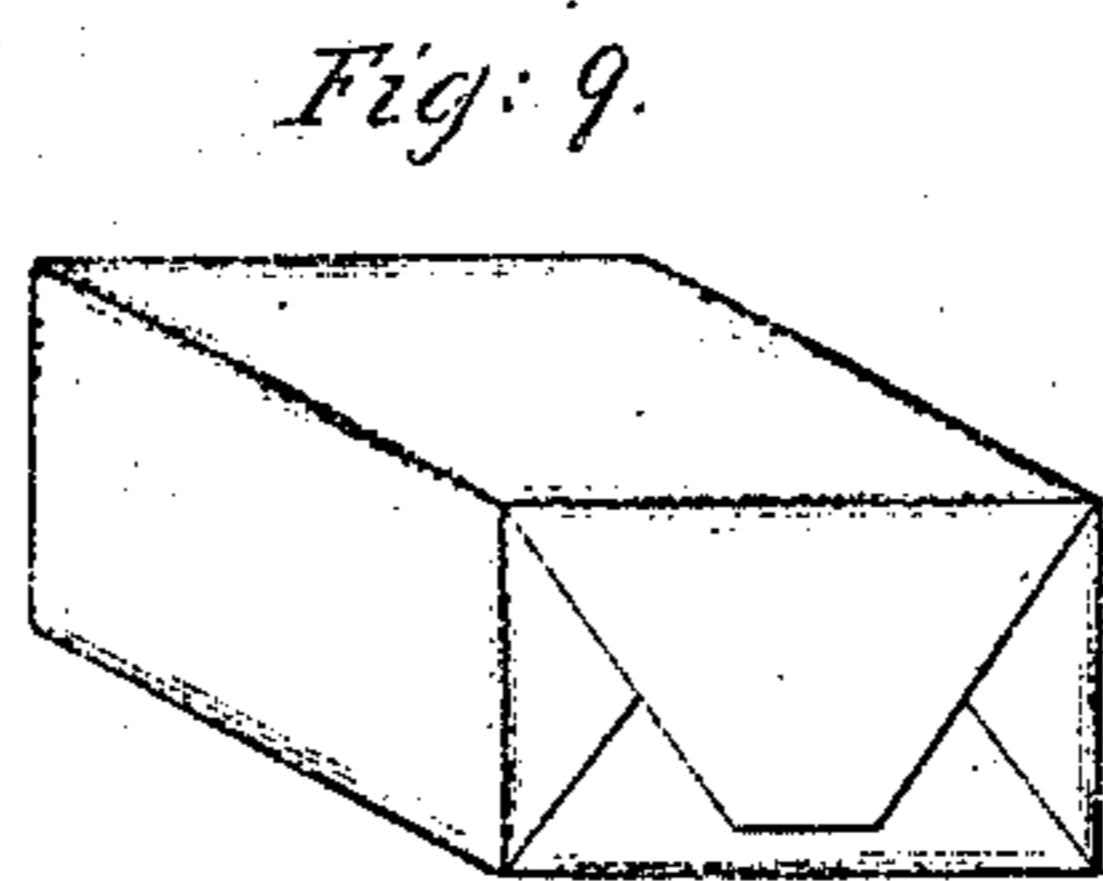
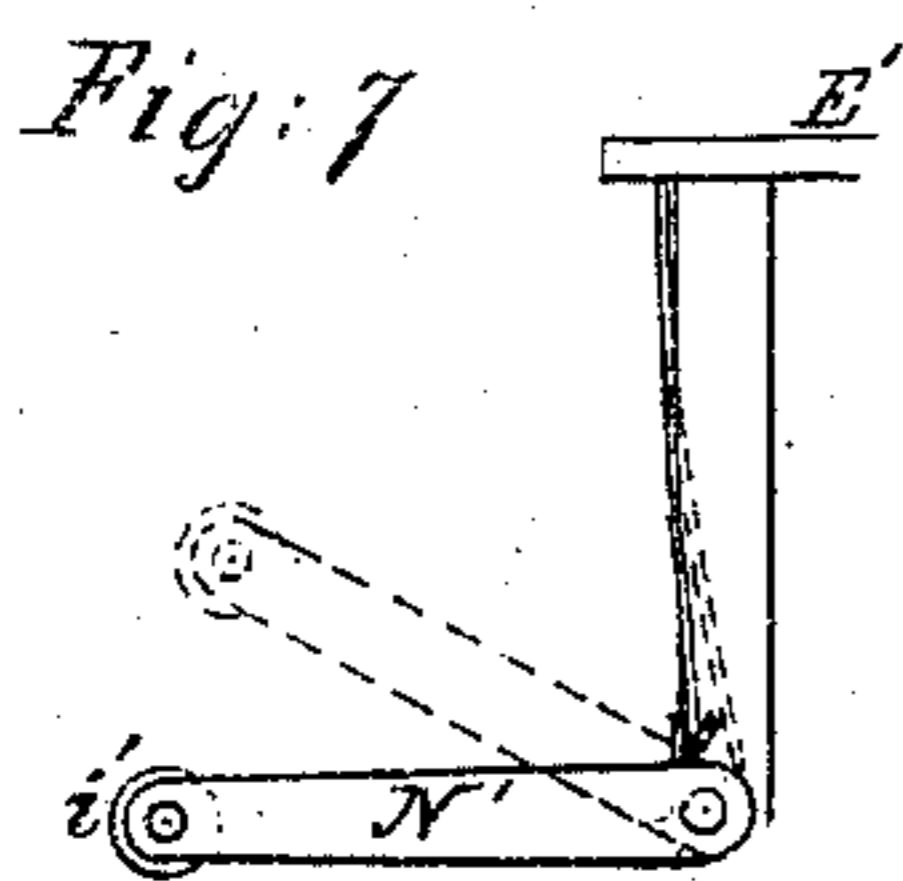
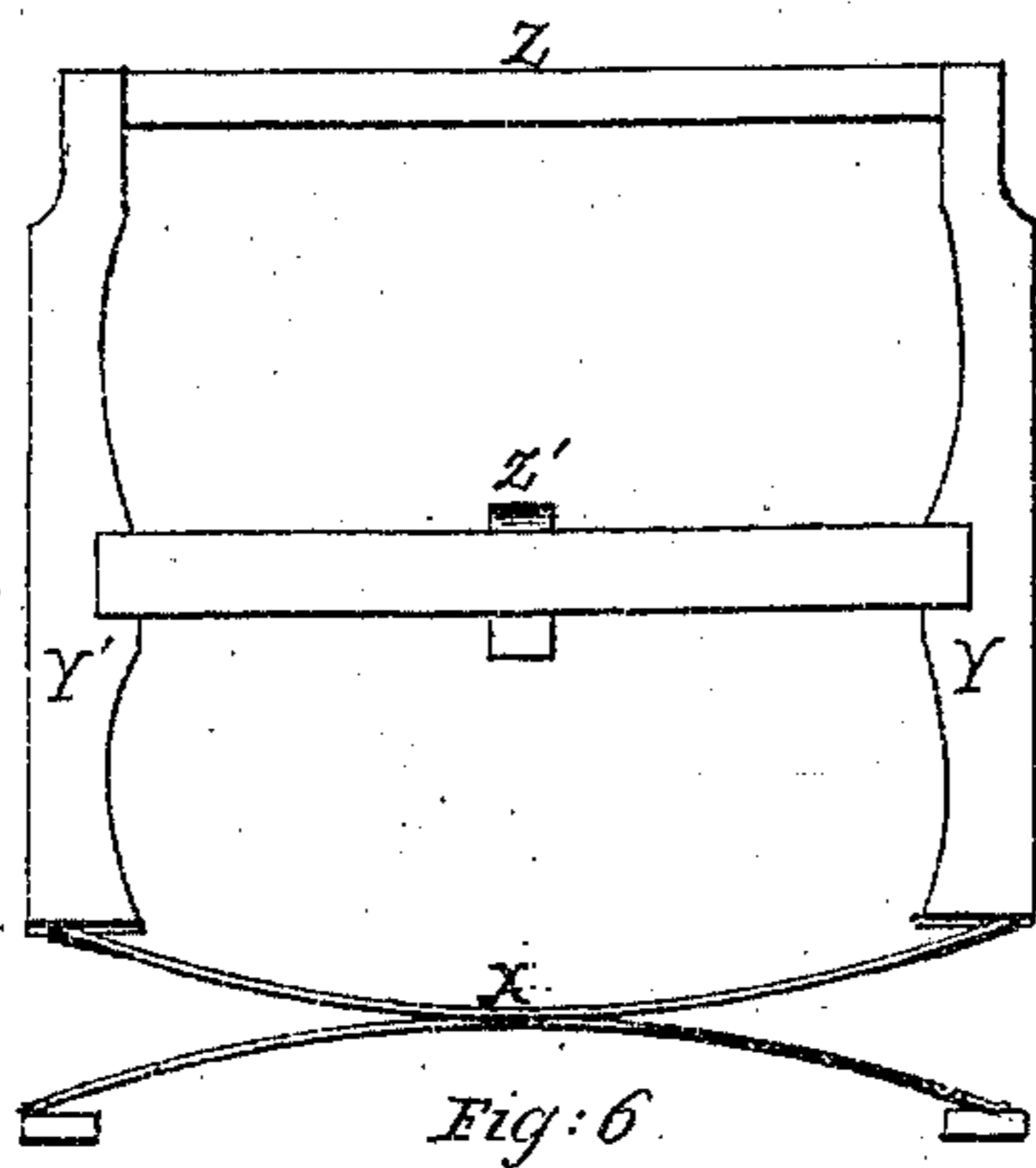

Witnesses

W. W. Deane

Geo. C. Lambright

Inventor

Margaret E. Knight

By her Attorney

Chas. F. Pansbury

UNITED STATES PATENT OFFICE.

MARGARETT E. KNIGHT, OF BOSTON, MASSACHUSETTS.

IMPROVEMENT IN PAPER-BAG MACHINES.

Specification forming part of Letters Patent No. 116,842, dated July 11, 1871.

To all whom it may concern:

Be it known that I, MARGARETT E. KNIGHT, of Boston, in the county of Suffolk and State of Massachusetts, have invented a new and Improved Machine for Making Paper Bags; and I do hereby declare the following to be a full and correct description of the same, reference being had to the accompanying drawing, in which—

Figure 1 is a front-side elevation of the machine. Fig. 2 is a plan or top view. Fig. 3 is a rear-side elevation. Fig. 4 is an elevation of the feed end, and Fig. 5 is an elevation of the delivery end of the machine. Fig. 6 is a front elevation of the severing-knife and frame. Fig. 7 is a side view of the guide-finger. Fig. 8 is a view of one of the side-folders and its operating parts. Fig. 9 is a perspective view of the finished bag. Figs. 10, 11, and 12 show the successive folds of the paper tube.

The same letter indicates the same part wherever it occurs.

The nature of this invention consists in the peculiar construction of a machine for the manufacture of flat or satchel-bottom bags from a continuous tube of paper fed from a roll over a former, and cut, folded, pasted, and delivered in the manner substantially as hereinafter described.

In the drawing, A marks the frame of the machine, which supports the operative parts. B is the feed-shaft, on which is a roller, C, which operates, in conjunction with a smaller roller, J', in the former H', to feed the paper. The paper is fed from a continuous roll, and is bent around the former H', with the lap on the upper side of the former. The former H' is an oblong piece of wood, attached, by a depending bracket, G', to the gallows F' on the rear end of the frame. Near its forward end the roller J' is inserted in an opening formed to receive it, and co-operates with the larger roller C on shaft B in feeding the paper. Grooves or slits in the upper edge of the former H' receive the side bars of the follower I', which is an oblong metallic frame, the form and position of which are clearly shown in Fig. 2. A cam, D, on shaft B next the side framing operates a lever, K', which is pivoted to the frame at p'. This lever is connected, by rod L' and bent lever M', to an arm, y, attached to the follower. (See Figs. 2 and 4.) A spiral spring, Z, is attached by its free end to rod L' and by its fixed end to a cross-bar of the frame A, and reacts to

draw the rod L' downward and throw the follower forward. On the outer end of shaft B, but turning loosely on it, is a cam, E, attached to a gear-wheel, J, which cam operates the plate-knife-folder F. I use the term "plate knife-folder" to indicate the device consisting of the arms a b, blade c, and cross-brace d, and mark the whole by the letter F. The blade c of this plate-knife-folder is attached to arm b, jointed to arms a, which are united by the cross-brace d and hinged or pivoted to the frame. A pin, e, projecting laterally from one of the arms a, rests on the face of the cam E and transmits motion to the knife. The ends of the blade c work in curved guide-ways e', which give direction to the movements of the knife, carrying the blade downward and forward during half its stroke and backward and upward during the other half. The winch G indicates the point of application of the driving power, at the end of the shaft P, to the cogged gear H. This gear is connected with a train of gearing, by which the operation of the machine is effected. Gear H, by means of the reversing-gear I, imparts the proper motion to the gear J, carrying the cam E, which operates the plate-knife-folder F, as before stated. By means of reversing-gear K it gives the appropriate motion to gear L on the end of the principal shaft Q. On shaft P is a cam, Z', Figs. 5 and 6, which operates to depress the frame of knife Z, the upward movement of said frame being given by the double spring X, which reacts in opposition to the downward motion of the cam. The spring X extends from side to side of the frame A, as shown in Figs. 4, 5, and 6, and receives the lower ends of the side pieces Y Y' of the knife-frame. On the shaft Q are fixed the two bevel-gears R and T, engaging, respectively, with the bevel-gears S and U hung to brackets on the inside of the side framing of the machine. These gears S and U operate the side-folders Q' R' by means of eccentric pins working in the angular slots u' v' in the downwardly-projecting shafts or stocks V V' of those side-folders. Spiral springs W W', reacting downward, give motion in that direction to the folder-stocks V V' when released from the upward action of the pins on the gears S and U. This arrangement is clearly shown in Fig. 8. M, Fig. 5, marks a reversing-gear driven by gear L on end of shaft Q. On the same shaft as M, and attached to it, is a larger gear, N, which drives

cogged pinion O on the end of folding-roller S. The roller *s* is one of a series of rollers, *r s t*, at the delivering end of the machine, which receives motion from *s*. They are held in their places by the spring-guards *c' d'*, which allow them the necessary amount of yielding play. In front of rollers *r s*, and between rollers *s* and *t*, plays the vertical knife D' attached to the rod *h*, having the slot *i* in its upper end, receiving the pin *j*, on which the rod *h* has vertical reciprocating motion. It is operated by lever *g*, having its fulcrum on end of stud *k* and pivoted to rod *f*, the lower end of which rod is bent around and operated downward by a cam on the inner side of gear-wheel C'. The lower end of *f* is pivoted to a vibrating arm, *m*, pivoted to the frame, and is forced upward by a coiled spring, *l*, the fixed end of which is attached to the side frame and its free end to the outer end of arm *m*. The gear C', which operates the knife D' by the mechanism just described, is itself driven by a reversing-gear, B', receiving motion from a gear, A', on the end of shaft Q. (See Fig. 3.) On the inner side of gear C' is a pin eccentrically placed, which operates bent arm or lever *n*, to which is attached the pasting-knife *p*. Spring *q* tends to keep arm *n* up. This paster works over a guide, *o*, which directs its movements, aided by a spring. A paste-roller, *b'*, is supported upon arms *a'*, projecting up from the frame. It is supplied with paste from a suitable reservoir, and supplies paste to the blade *p*. From gallows E' projects downward a standard, to the lower end of which is pivoted the guide-finger N', having the roller *i'* on its free end. A flat spring (see Fig. 7) attached to the standard and acting against a pin on the upper edge of the guide-finger tends to throw the finger downward. This spring is counteracted by the bent arm *h'*, to which the finger is attached, and the outer end of which is operated by a cam, S', on the inside of gear A', on the end of shaft Q, as shown in Fig. 3. O', Fig. 2, marks the straight edge against which the severing-knife Z plays, and P' the metallic plate or table on which the folders operate.

Having thus described the construction of the machine, its operation is as follows: The paper from which the bags are to be made is drawn from a roll of indefinite length, suspended so as to be unwound and supplied to the machine as fast as required. It is folded around the former H', with the lap on the upper side, and the pasting, which makes it a continuous tube, is effected by suitable devices for that purpose. All these devices, being well known, are omitted from the drawing. The feed-shaft B receives intermittent motion, by means of intermediate gears, from an eccentric gear on the opposite end of shaft P from that to which the winch G is represented as attached, as in Fig. 2. This mode of producing a stop-motion, being a familiar one, is not represented in the drawing. The gearing is so adjusted as to arrest the motion of the shaft B, and consequently that of the paper tube, at the instant when, as hereinafter described, the folders Q' R' are holding down the forward end of the tube and the bag is being cut off from it by

the severing-knife Z. The motion is resumed when the folders Q' R' are drawn back and the tube is released from their grasp. The feed of the tube is produced by the action of the two rollers C and J', the former turning in contact with the bottom of the paper tube and the latter on the inside of the tube, and the two nipping the paper between them and impelling it forward. The follower I' starts with the paper and moves with it until it reaches the guide-finger N', when it is drawn back by the operation of the spring *z*. The blade *c* of the plate-knife-folder F, operated by cam E, takes the paper, which is still held open by the guide-finger N', and carries it under that finger, which, as the paper passes under, pushes back the middle of the upper side of the tube, so as to give the peculiar form represented in Fig. 10 to the first fold. The blade *c*, still going with the paper as it feeds, passes under the side-folders Q' R' until the point *q'* of the paper is taken by the rolls *r s*. The plate-knife-folder F now draws back, the folders Q' R' close down upon the tube, and the feed-motion stops. The blade *c* now passes over the side-folders Q' R' again, making the second fold, as represented in Fig. 11, the guide-finger N' rising to let the fold of paper pass under it, and dropping again to hold it in its place. The blade *c* going back, the side-folders draw apart, and the first half of the bottom of the bag is made. The paper now passes between the rollers *r s*, the vertical knife D' descends and passes, with the paper, between the rolls *s* and *t*, making the third fold, represented in Fig. 12, and completing the other half of the bag bottom. At this point, and just before the fold is made, paste is applied to the bottom of the bag by the paster *p*, which receives paste from the small paste-roller *b'*, and is operated by its connection with the gear C', as hereinbefore described. The severing of the bag from the paper tube is effected during the arrest of the feed-motion, as hereinbefore mentioned, by a vertical knife, Z, attached to a frame and operated by the cam Z on shaft P. It plays against a steel straight-edge, O', parallel to the edge of the table P', (see Fig. 2,) the two forming a species of shears, capable of cutting paper, cloth, or any other material applicable to the manufacture of bags.

I wish to have it understood that, believing myself to be the first to invent a device to hold back or push back a point or portion of one edge of the paper tube while the blade or tucking-knife forms the first fold, represented in Fig. 10, which is the basis of the flat-bottomed bag, I do not confine myself to any particular form, position, or mode of attaching the device referred to, which I have designated a "guide-finger," nor limit myself to making it fixed or movable, as long as it performs the function for which I have devised and use it. I have made it in various forms, and fixed as well as movable, and having a rearward projection like a heel. The guide-finger hereinbefore described I believe to be of the best form; but other forms will answer, with the necessary modifications of the accompanying mechanism, without altering the principle of op-

eration by which the fold represented in Fig. 10 is made.

Having thus fully described my invention, what I claim, and desire to secure by Letters Patent, is—

1. The follower I', constructed and operating as and for the purpose specified.

2. The plate-knife-folder F, constructed, arranged, and operating as set forth.

3. The guide-finger N', or equivalent device, whether fixed or movable, the function of which is to hold or push back a portion of the edge of the paper tube while the fold represented in Fig. 10 is being formed.

4. The combination of a guide-finger with mechanism or a device for pushing the paper tube under said guide-finger, for the purpose of forming the fold represented in Fig. 10.

5. The side-folders Q' R', constructed, arranged, and operated by the means described, as and for the purpose specified.

The above specification of my said invention signed and witnessed at Boston this 9th day of November, A. D. 1869.

MARGARETT E. KNIGHT.

Witnesses:

SAML. C. MOORE,
JOHN WHEELLOCK.