

T. Blanchard,
Wood Molding Machine.

Patented Aug. 10, 1836.

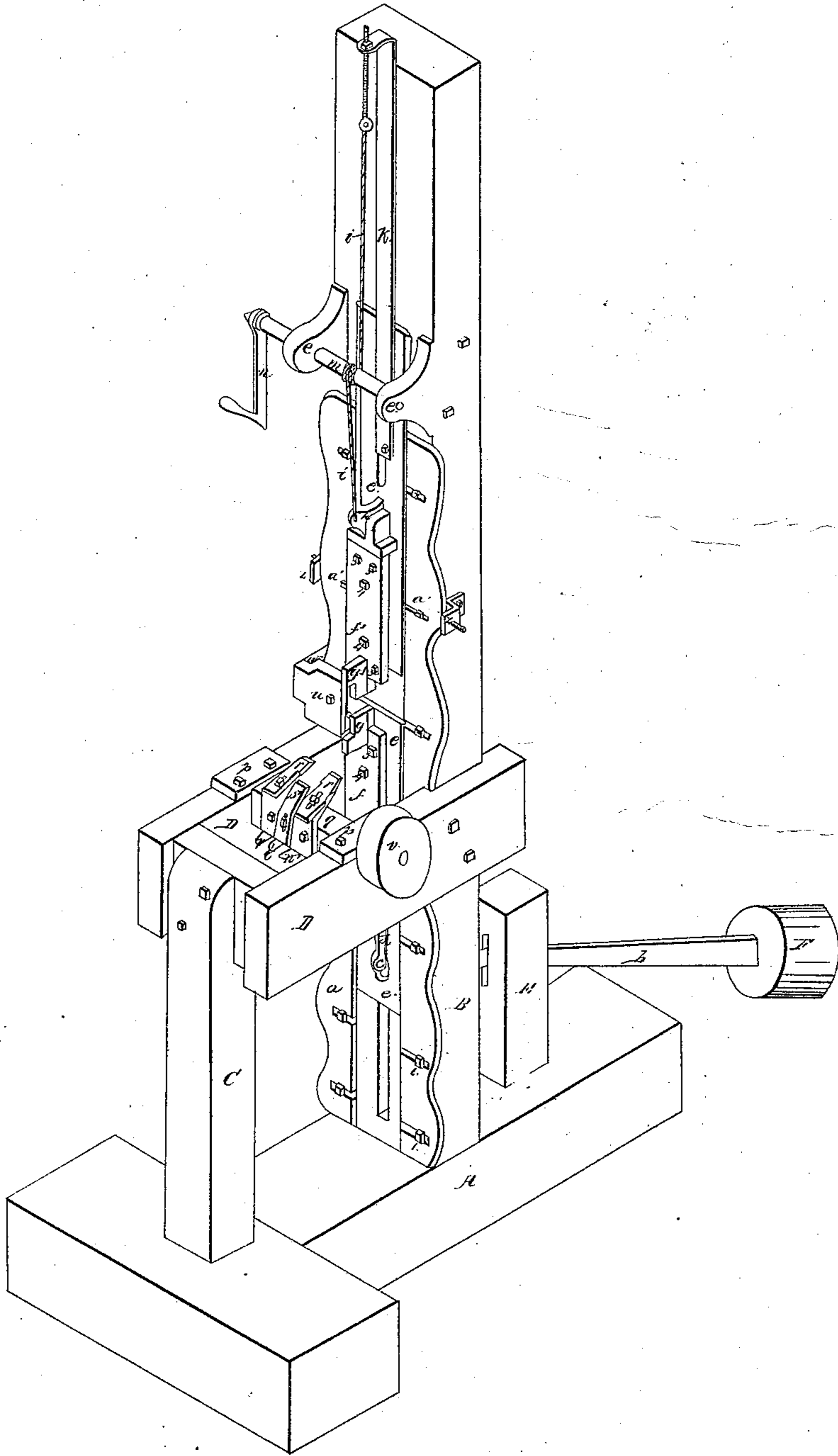

UNITED STATES PATENT OFFICE.

THOMAS BLANCHARD, OF NEW YORK, N. Y.

MACHINE FOR FORMING END PIECES OF PLANK BLOCKS FOR SHIPS, &c.

Specification of Letters Patent No. 6, dated August 10, 1836.

To all whom it may concern:

Be it known that I, THOMAS BLANCHARD, of the city, county, and State of New York, have made certain new and useful improvements in machinery for forming parts of made tackle-blocks, or, as they are technically called, plank-blocks, for ships and other purposes in a better manner than has been done by hand or in any other way, and that the said improvement and the machinery by which the same are effected and the method of constructing and using the same are fully and correctly set forth in the following specification and in the drawing annexed to and making a part of this specification, wherein—

The principal figure represents the machine I use for the purpose of making the end pieces of plank, or made blocks, and the several parts thereof are as follows: A, is a lower bearer. B, is an upright standard post in the bearer A. C, is a small post in front to support D, D, two bearing blocks connected at one end to B, and E, is a small post behind serving as a fulcrum post. These are the fixed parts represented as of wood, but may be made of iron, on which the working parts of the machine are mounted.

a , a , are two lower, a^1 , a^1 are two upper metal slide ways with slots through which they are screwed, and adjusted into the standard B, by screw bolts 1, 1, 1, 1. These slide ways may if so chosen be made in one piece on each side. The side set screws 2, 2, 2, 2, give, and retain the lateral position of these ways as wanted.

b , is a balance lever one end sliding in a mortise in the standard B, and having the fulcrum on a bolt in the part E. At the back end of this lever is the weight F, and the other end coming through a slot in the side piece e , in front of the post, B, the joint c , connects the lever to the lower end of the rod d , and this connecting rod is again jointed to the middle part of the lower slide piece e , which has a shoulder flanch, or step near the middle to receive the stop of the lower carrier block f , with the lower center bracket g , upon it. These are screwed to the slide piece by holding screws 3, 3, and adjusted by set screws 4, 4. Above in the slide way the upper slide piece e^1 , is set in reverse with the lower slide e , and has the corner block f^1 , and center bracket, g^1 , on the lower bracket, and held, and ad-

justed by screws 3¹, and set screws 4¹, in the same way, and on the part corresponding to the joint on the lower slides is the eye h , and to this is fastened the cord i , over the slot in the slide above this is the vertical guide rod k , held by bolts through the slot, and having at top a return end projecting out in front at right angles.

In the bearings l , l , is mounted the small winch m , moved by the small crank handle n . The cord i , goes round this winch, and up toward the guide rod k , when the cord is fastened through the eye of the adjusting screw eye bolt O, so that the slide f^1 , may be moved up, or down by turning the crank handle n , but the same object may be obtained by a rack, and pinion, or a small chain in place of a cord. Upon bearings p , p , in the blocks D, D, the revolving cutter shaft q , is mounted made square between the bearings p , p , having on it two pairs of straight edged cutters r , r , which edges are at right angles to the cutter shaft center with the cutting edges inward facing each other, and fitted to stand in cutting at the angle with a carpenter's plane iron having slots in their stocks to allow of adjustment, and fixture by screws going through the slots into the stock, brackets, and bearings on the shaft of, and between the stock brackets of these two cutters, on the other flat sides of the shaft q , are fixed the straight edged cutter S, and the round edged cutter t , also held by screws through slots to allow of their adjustment. The drum, or pulley V, gives motion to the cutters by a belt, or band to any first mover, and the use of this machine as thus described is to shape the pieces forming the ends of the mortices in made, or plank blocks in the following manner. If the workman intends to form the hollow, or head end piece of a block, he adjusts the round edged cutter t , in advance by withdrawing the straight edged cutter S, so much as may be needed to leave the round edged cutter to operate in cutting the hollow with a clear edge, and if he wishes to cut the piece forming the square end, or as it is technically termed, the arse end of the mortise in the block, he withdraws the round edged cutter from operation, and advances the straight edged one. In either case adjusting the right angled cutters r , r , to strip the sides of the piece of wood exactly to the thickness required by the mor-

tise of the intended block before he begins to work the machine, then a piece cut nearly to the length required is placed endwise upon the lower center bracket *g*, where the
 5 lateral position is adjusted by the gage piece in working by a screw through a slot into the gage bracket *w*. The workman now turns the small winch *m*, by the crank
 10 handle *n*, so that the upper center bracket *g*¹, comes down, and holds the piece of wood firmly between the two brackets, and the workman continuing to turn the winch overcomes the resistance of the balance lever *b*, and the weight *F*, and forces the lower
 15 slide piece *e*, and its fixtures downward so as to carry the piece of wood entirely below the operation of the revolving cutters. By this means the wood in the passage from the upper to the lower is entirely stripped of all
 20 superfluous material on three sides, and reduced exactly to the shape, and size which is required in setting up the block about to be made. The workman reversing the operation at the winch *m*, brings the piece up
 25 again, and removes it, leaving the space between the center brackets open for other

pieces to be successively formed in a similar manner. And I the said THOMAS BLANCHARD do hereby claim as my invention—

The application of rotary or revolving 30 cutters acting at right angles to the shaft to which they are affixed, and set at a cutting angle similar to that of a carpenter's plane iron so as to form a clean drawing stroke with the grain of the wood to be op- 35 erated on together with the round edged, and straight edged cutters parallel to the shaft, as the same are herein substantially set forth, and described as being applied by me to the purpose of thereby forming at 40 one operation three sides of the end pieces for made tackle blocks of any required size. And the adaptation, and combination of all the parts, aforesaid in any manner substan- 45 tially the same as that above described, and so as to produce the aforesaid results.

In testimony whereof I have hereunto set my hand Aug. 11th, 1835.

THOS. BLANCHARD.

Witnesses:

JOHN N. TAYLOR,
 JAS. H. SANFORD.